

Installation Instructions & Owner's Manual
SG5000LS with Standard Track

For professional installers only
Keep this document in a safe place for future reference

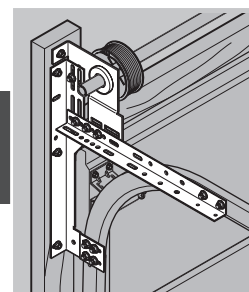

Standard Track

Dear Customer,

Congratulations on your purchase of a Hörmann SG5000LS garage door. It has been designed to provide years of trouble-free operation.

Please see the Owner's Manual on page 28 for the safe operation of your new garage door, as well as its care and maintenance instructions. Please keep this document for future reference.

We kindly ask you to fill in the information required and to have it available in case you need to call us for assistance.

Hörmann High Performance Doors

CONSUMER-HOTLINE: 1-800-365-3665

| INDEX | PAGE |
|---|------|
| Tools required for the installation of the garage door | 3 |
| Contents | 4/5 |
| Introduction | 6 |
| Basic Door Measurement | 7 |
| Mechanical Installation | 8 |
| Residential Door Warranty | 28 |
| Owner's Manual | 30 |



PLEASE SEE PAGE 6 FOR IMPORTANT
WARNINGS AND INSTRUCTIONS
 TO PREVENT **INJURY** OR **DEATH**.

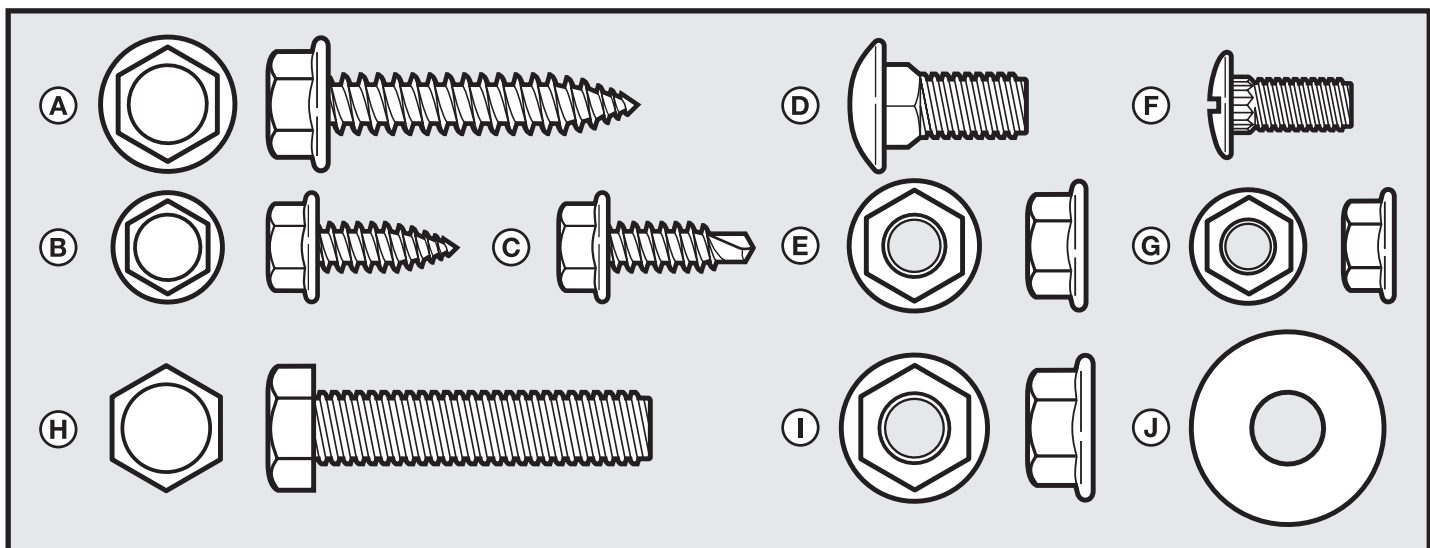
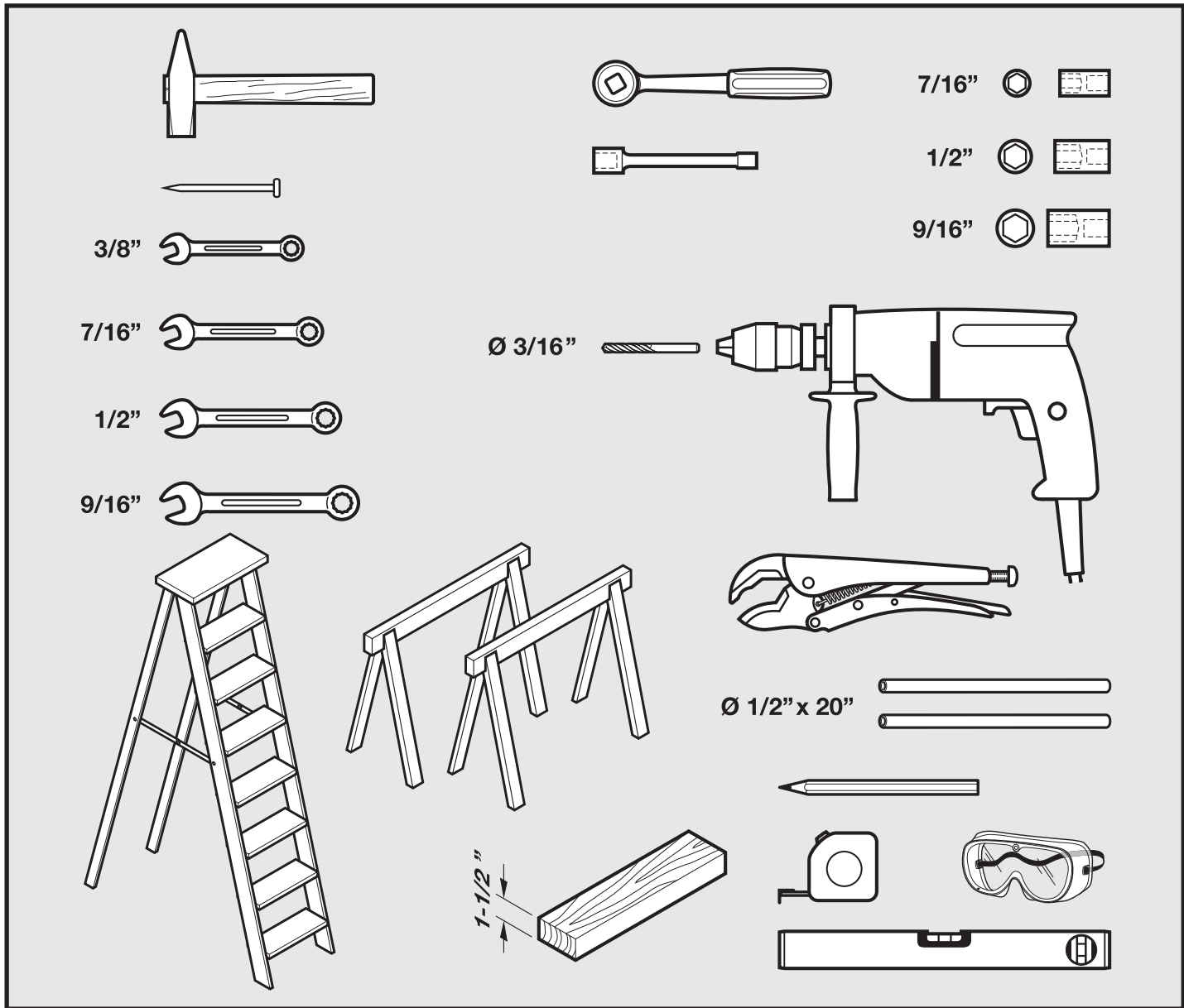

CONTENTS

| Item | Contents | Fig. |
|-------|---|-----------|
| 1 | Bottom section | 2 |
| 2 | Intermediate section | 3 |
| 3 | Intermediate section | 4 |
| 4 | Top section | 4 |
| 5 | Pair of roller holders # 1 | 2.1 |
| 6 | Pair of roller holders # 2 | 3.4 |
| 7 | Pair of roller holders # 3 | 4.2 |
| 8 | Intermediate hinges | 2.1/3.4 |
| 9 | Rollers | 4.5 |
| 10-11 | Bottom bracket | 2.3 |
| 12 | Center hinges | 2.2/3.3 |
| 13 | Opener bracket | 4.3 |
| 14 | Top section roller holders | 4.2 |
| 15 | Jamb brackets | 5 |
| 16 | Flag angle inside left | 6 |
| 17 | Flag angle inside right | 6 |
| 18 | Horizontal angle | 6.3 |
| 19 | Punched steel angles (not included) | 7 |
| 20 | Bottom weather seal | 2.3 |
| 21 | Vertical track left side | 5 |
| 22 | Vertical track right side | - |
| 23 | Horizontal track left side | 6.4 |
| 24 | Horizontal track right side | - |
| 25 | Cable | 2.4/9 |
| 26 | End bearing support left | 8.1 |
| 27 | End bearing support right | - |
| 28 | Center bearing support | 8.3 |
| 29 | Cable drum inside left (red-RW) | 8.3 |
| 30 | Cable drum inside right (black-LW) | 8.3 |
| 31 | Torsion spring (black) | 8.3 |
| 32 | Torsion spring (red) | 8.3 |
| 33 | Shaft | 8.3 |
| 34 | Horizontal reinforcement (if supplied) | 4.2b/4.3b |
| 35 | Side shield | 4.5 |

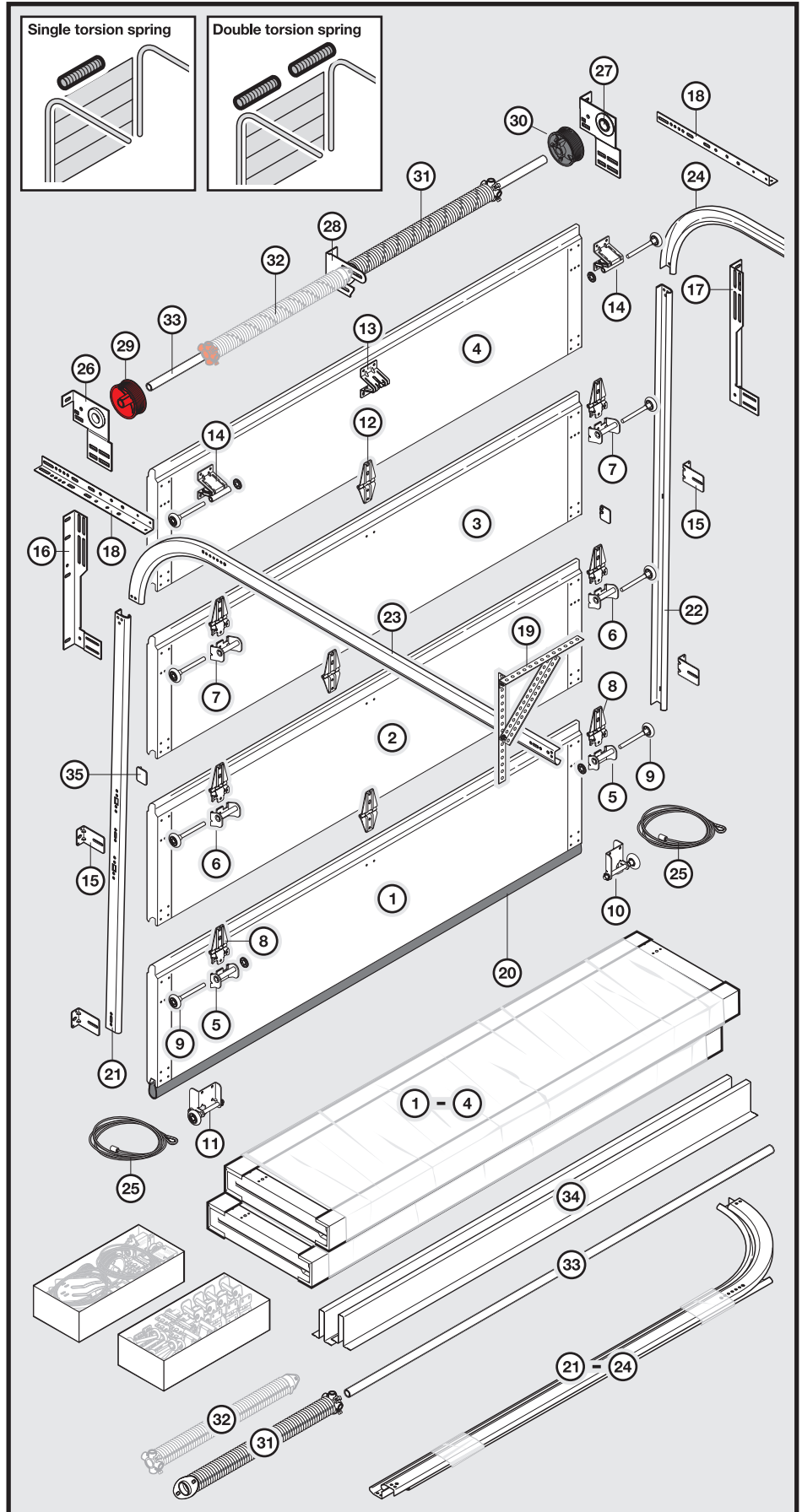

CONTENTS

| Item | Contents | Fig. |
|-------|---|-----------|
| 1 | Bottom section | 2 |
| 2 | Intermediate section | 3 |
| 3 | Intermediate section | 4 |
| 4 | Top section | 4 |
| 5 | Pair of roller holders # 1 | 2.1 |
| 6 | Pair of roller holders # 2 | 3.4 |
| 7 | Pair of roller holders # 3 | 4.2 |
| 8 | Intermediate hinges | 2.1/3.4 |
| 9 | Rollers | 4.5 |
| 10-11 | Bottom bracket | 2.3 |
| 12 | Center hinges | 2.2/3.3 |
| 13 | Opener bracket | 4.3 |
| 14 | Top section roller holders | 4.2 |
| 15 | Jamb brackets | 5 |
| 16 | Flag angle inside left | 6 |
| 17 | Flag angle inside right | 6 |
| 18 | Horizontal angle | 6.3 |
| 19 | Punched steel angles (not included) | 7 |
| 20 | Bottom weather seal | 2.3 |
| 21 | Vertical track left side | 5 |
| 22 | Vertical track right side | - |
| 23 | Horizontal track left side | 6.4 |
| 24 | Horizontal track right side | - |
| 25 | Cable | 2.4/9 |
| 26 | Sheave | 8.1 |
| 27 | S-Hook | - |
| 28 | Cable end | 8.3 |
| 29 | Clevis for sheave | 8.3 |
| 30 | Spring | 8.3 |
| 31 | Open eye bolt | 8.3 |
| 32 | Rope tie | 8.3 |
| 33 | Horizontal reinforcement (if supplied) | 4.2b/4.3b |
| 34 | Safety cables | 9.6 |
| 35 | Side shield | 4.5 |

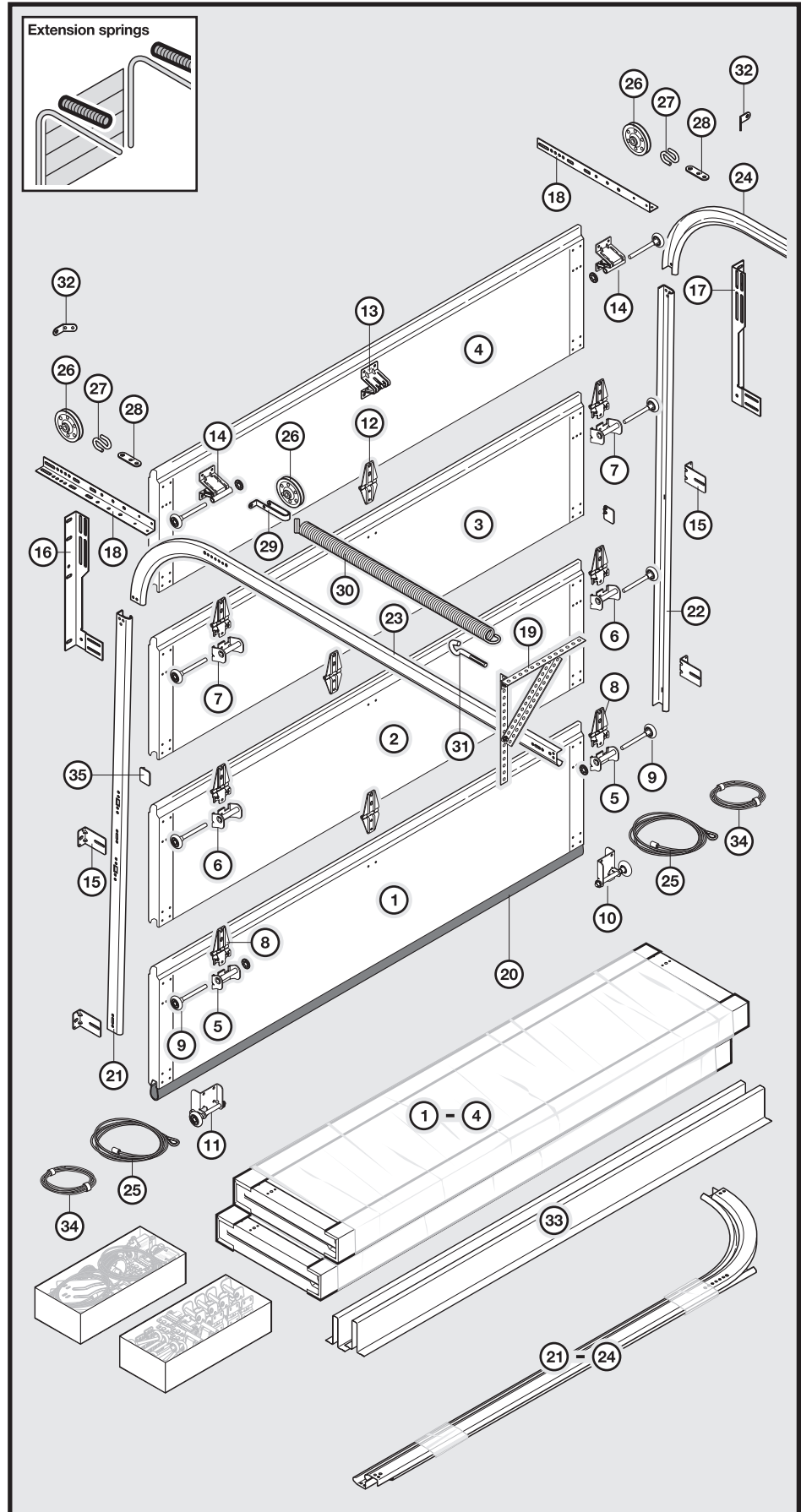

THE INSTALLATION OF THE DOOR MUST BE CARRIED OUT BY A PROFESSIONAL INSTALLER ONLY!



WARNING

Torsion springs can be very dangerous if they are improperly installed or mishandled. Do not attempt to install them yourself unless

- 1) you have the right tools and reasonable mechanical aptitude or experience and
- 2) you follow these Instructions very carefully.

ALWAYS USE GOOD QUALITY, SNUG FITTING, CONSTANT DIAMETER, SOLID STEEL WINDING BARS WHEN WINDING OR ADJUSTING SPRINGS. THE USE OF ANY OTHER OBJECT CAN RESULT IN SEVERE INJURY. WHEN WINDING THE SPRINGS, THE WINDING BAR MUST BE INSERTED INTO THE FULL DEPTH OF THE HOLES IN THE WINDING CONE. KEEP A FIRM GRIP ON THE WINDING BARS AT ALL TIMES. USE A STURDY LADDER AND STAND TO THE SIDE OF THE WINDING BARS.

IF YOUR DOOR HAS A TORSION SPRING ASSEMBLY, YOU MUST MAKE SURE THAT THE WOOD ANCHOR PAD (SEE DRAWING) IS FIRMLY ATTACHED TO THE GARAGE WALL AS DESCRIBED IN THE DETAILED INSTRUCTIONS ON THE NEXT PAGE. **FAILURE TO SECURELY ATTACH THE ANCHOR PAD COULD ALLOW THE SPRINGS TO VIOLENTLY PULL AWAY FROM THE GARAGE WALL, AND COULD RESULT IN SEVERE INJURY AND/OR PROPERTY DAMAGE. IN NO CASE SHOULD NAILS BE USED.**



WARNING

Make sure that all screws are fixed correctly. Loose screws can result in severe injury.



WARNING

To avoid injury, keep hands and fingers clear of section joints, hinges, tracks, springs and other door parts while the door is moving.

BASIC DOOR MEASUREMENTS

Pictured inside of garage looking out

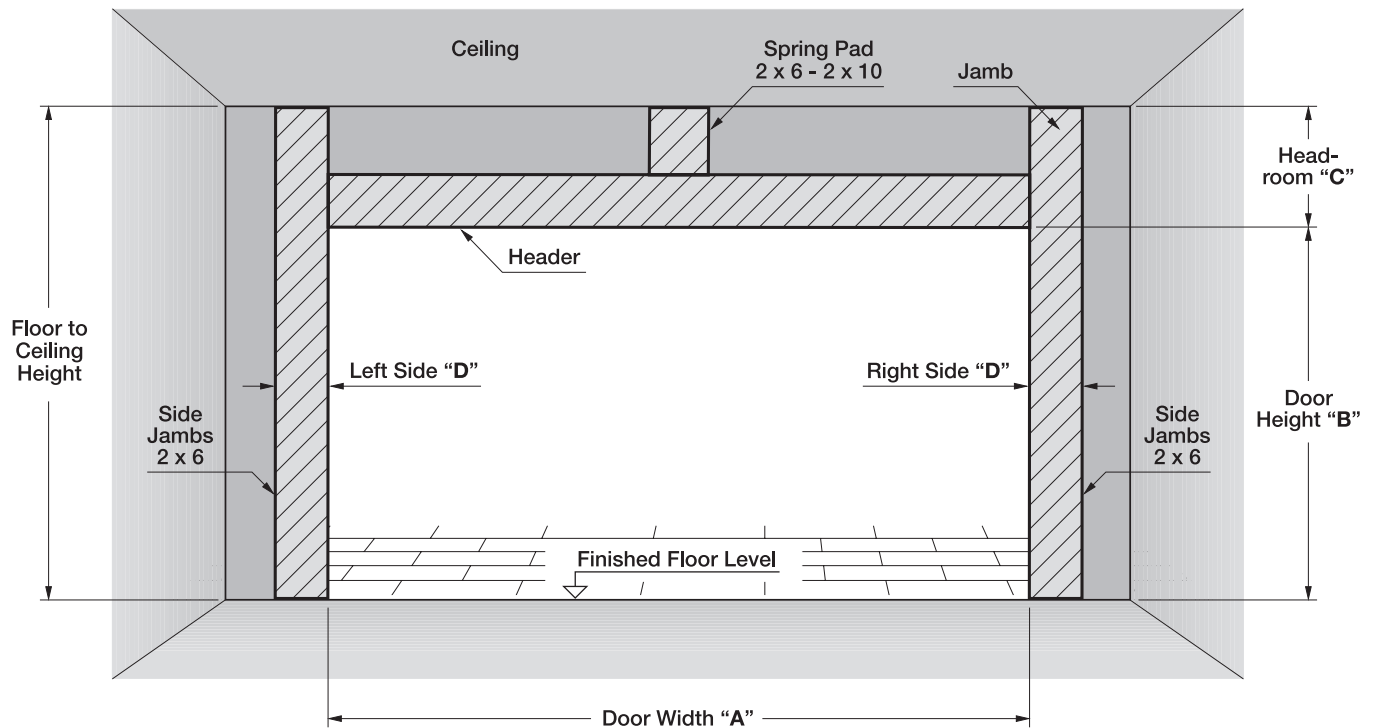

Measure your opening and fill in dimensions below:

Step 1: Measure the door opening width

Door Width

A = _____ ft _____ in

Step 2: Measure the door opening height

Door Height

B = _____ ft _____ in

Step 3: Measure the headroom

Headroom (*Requires minimum 12")

C = _____ ft _____ in

Step 4: Measure the Sideroom

Sideroom - left side

D = _____ ft _____ in

Sideroom - right side

_____ ft _____ in

(*Requires minimum 4" each side)

Note:

You must have at least twelve inches (12") headroom to install your new garage door. If you plan to use an electric opener, the headroom increases approximately three inches (3"). If headroom is less than twelve inches (12"), low headroom track option is available.

MECHANICAL INSTALLATION

PLEASE NOTE:
WOOD JAMBS SHOULD BE SECURELY
ANCHORED TO WALL AND JAMB
FASTENERS SHOULD BE FLUSH WITH
WOOD JAMBS.

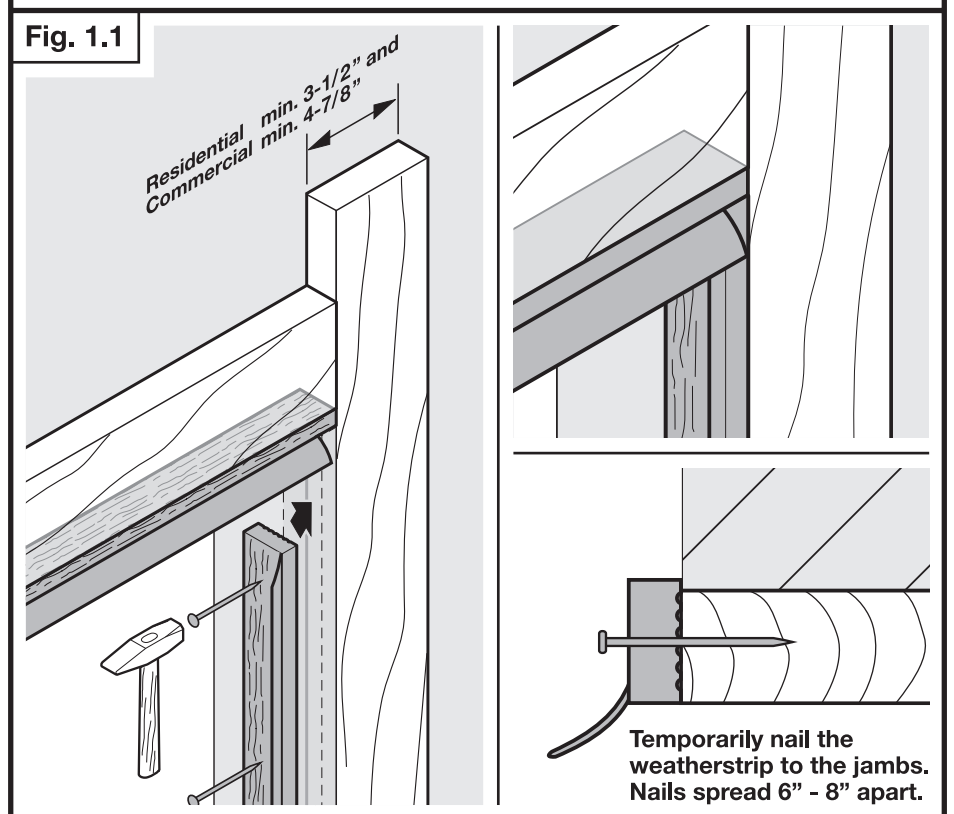
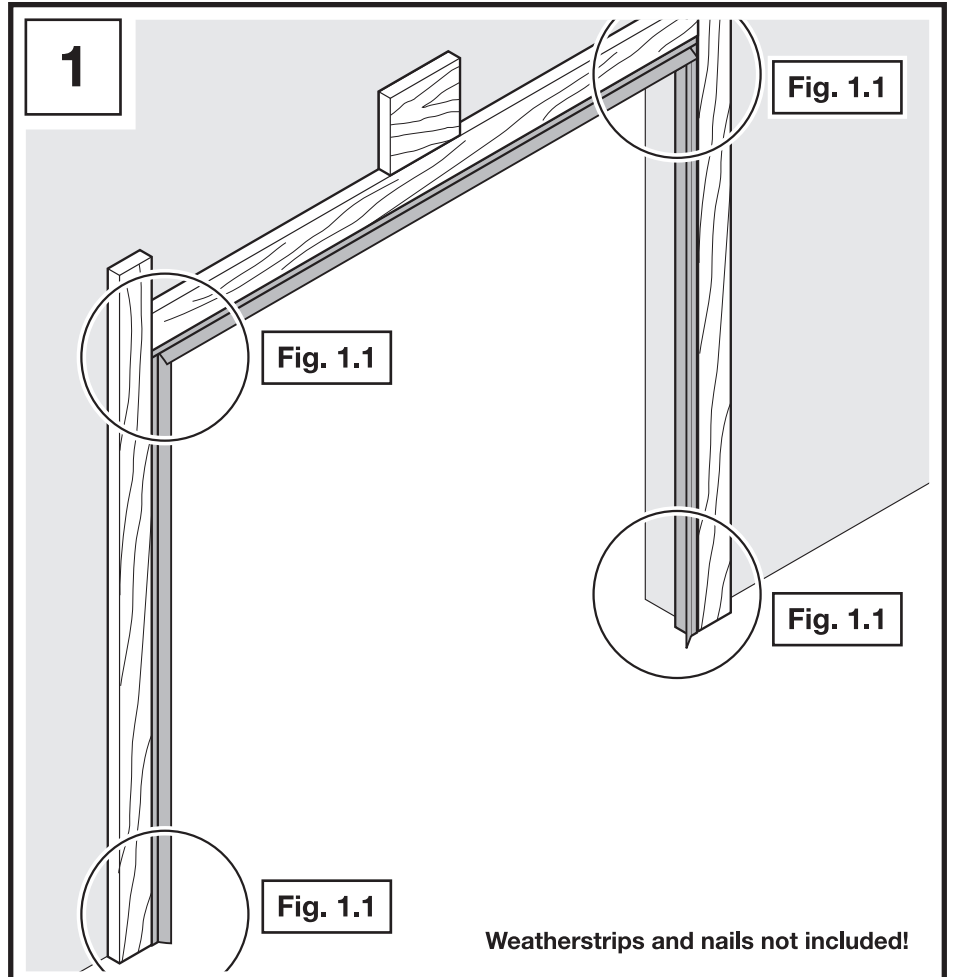

MECHANICAL INSTALLATION

Center Hinge

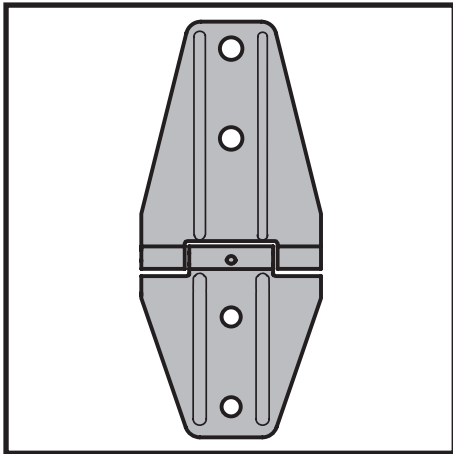

End Hinge

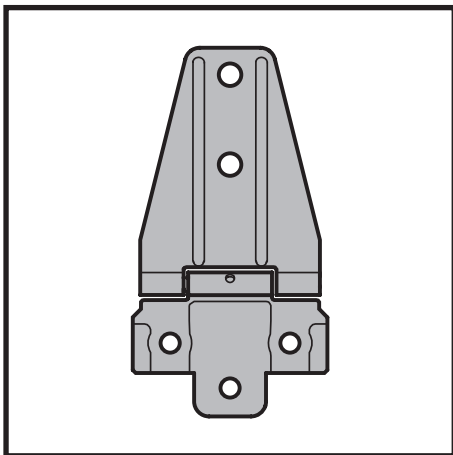

Roller Holder

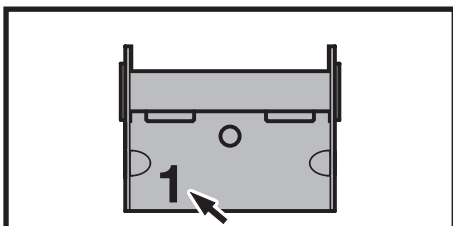

Note:
Roller holders are numbered to identify the location of installation.

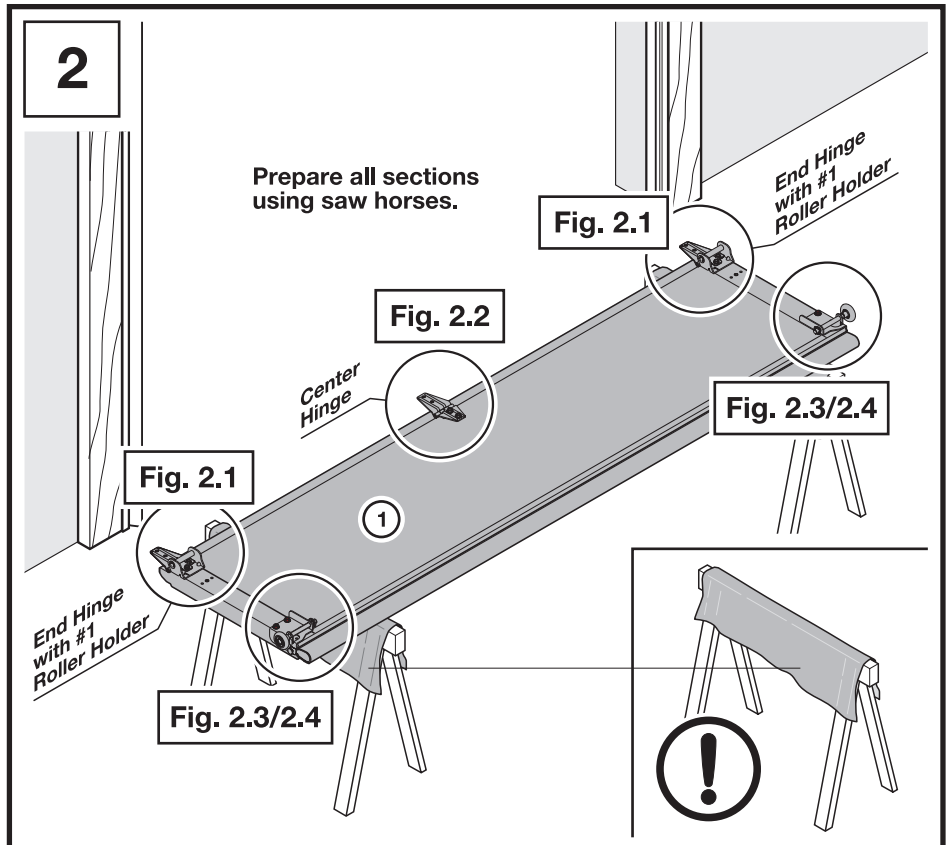

Fig. 2.1 End Hinge

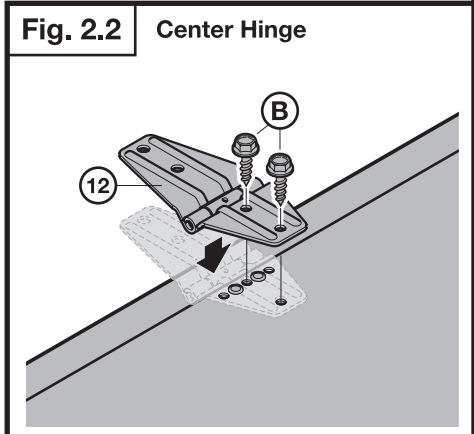
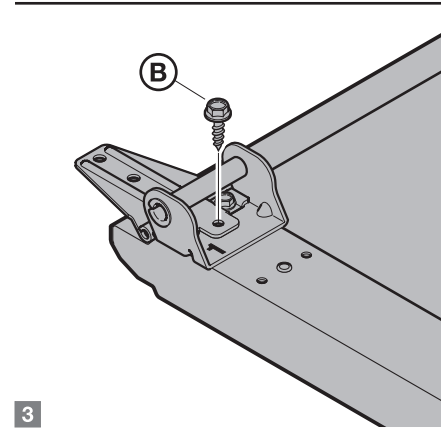
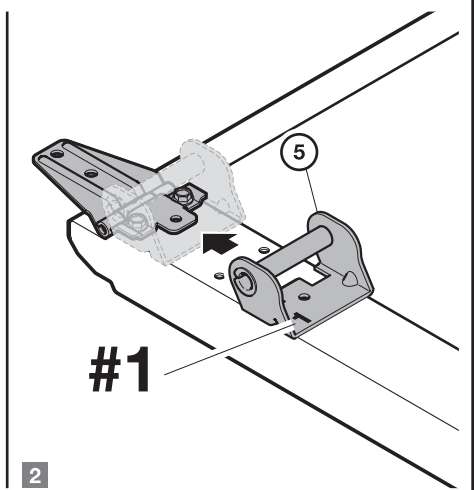
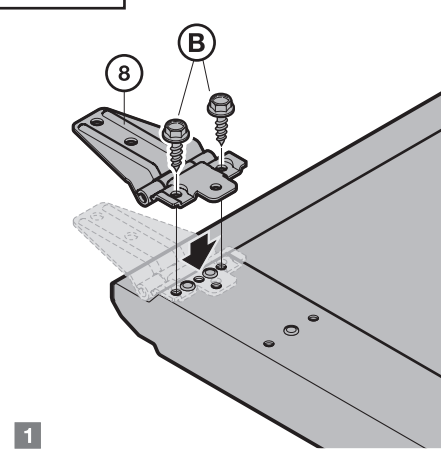
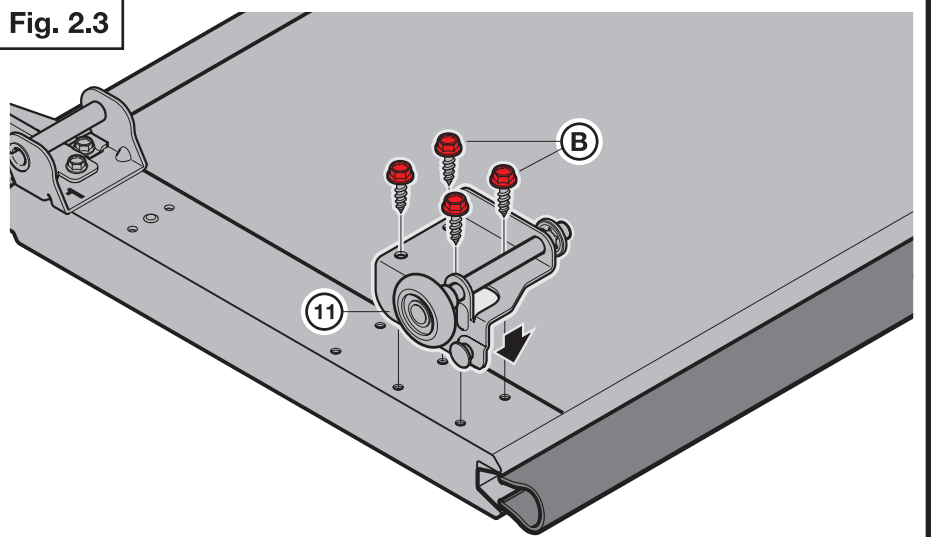
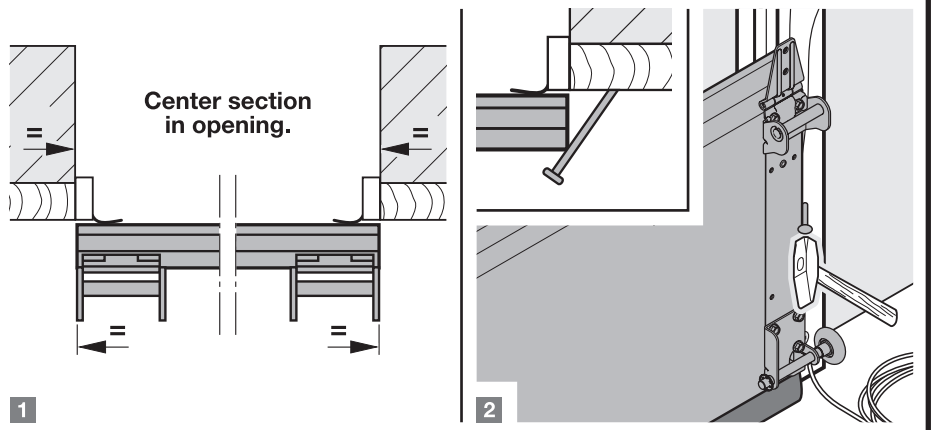
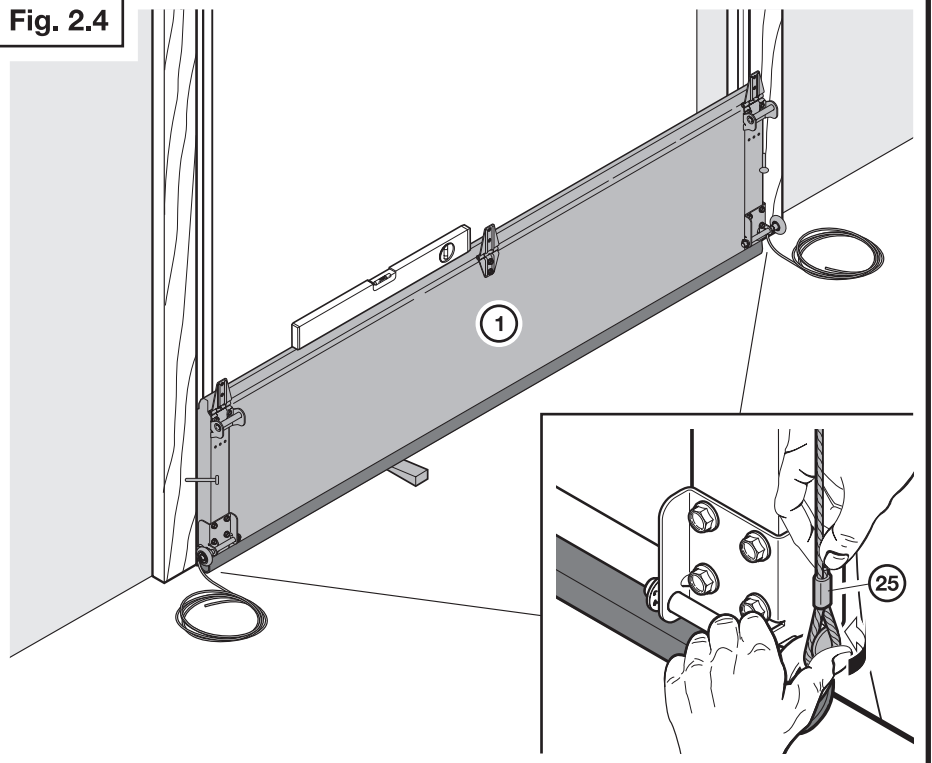

Fig. 2.3



INSTALL LOOPED END OF CABLE ONTO BOTTOM FIXTURE. PLACE BOTTOM SECTION IN OPENING CENTER AND LEVEL.
 TEMPORARILY SECURE SECTION WITH NAILS INTO JAMB AT EACH END OF SECTION. BEND NAILS SLIGHTLY AROUND SECTION TO HOLD SECURELY IN PLACE.

Fig. 2.4



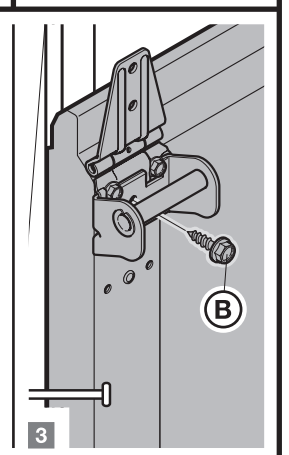
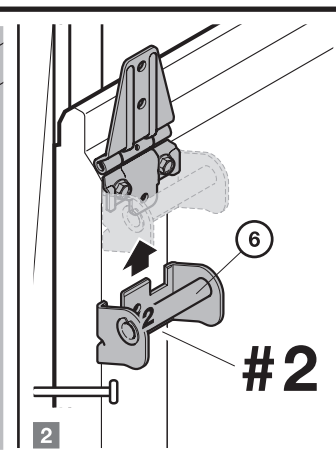
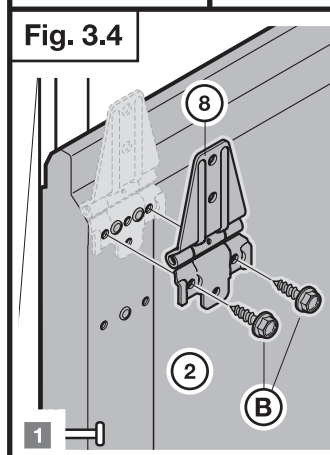
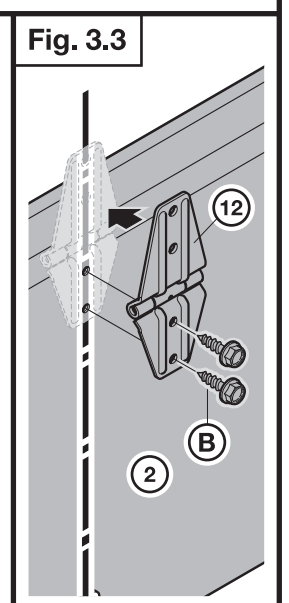
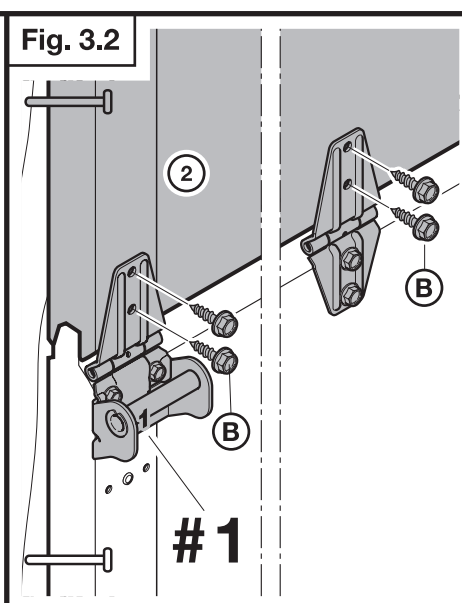
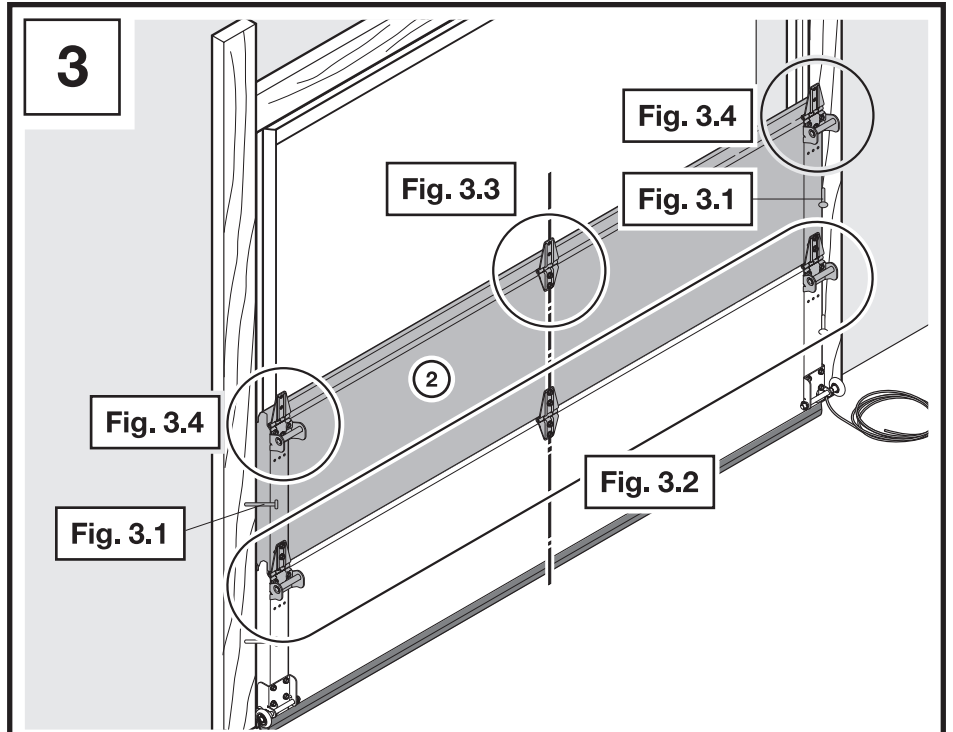

MECHANICAL INSTALLATION

Top section roller holder
with strut – see Fig. 4.2b

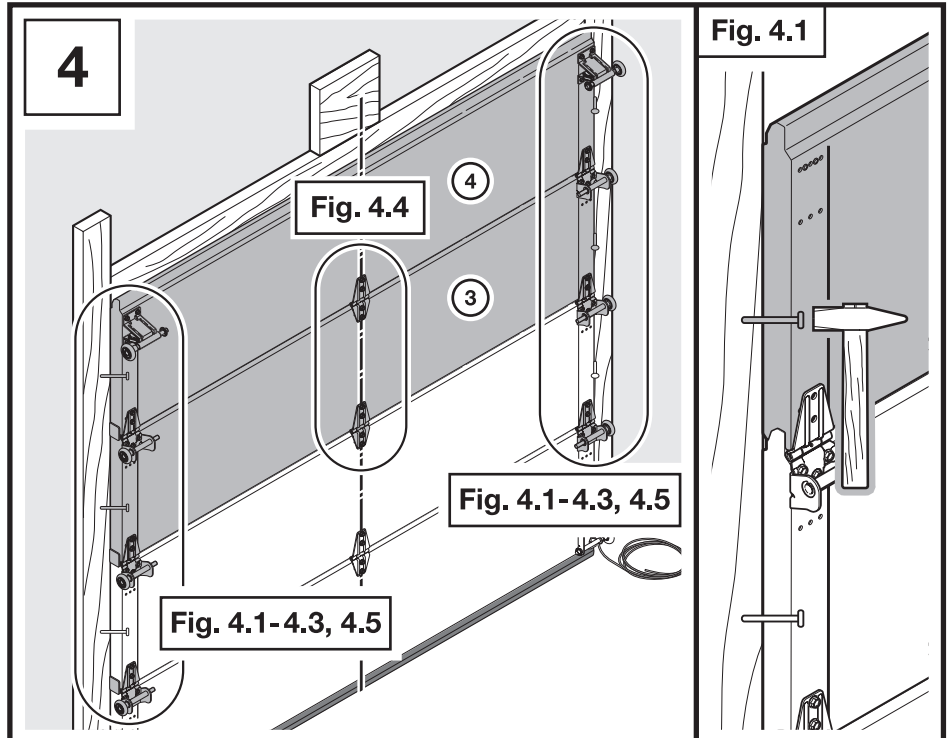
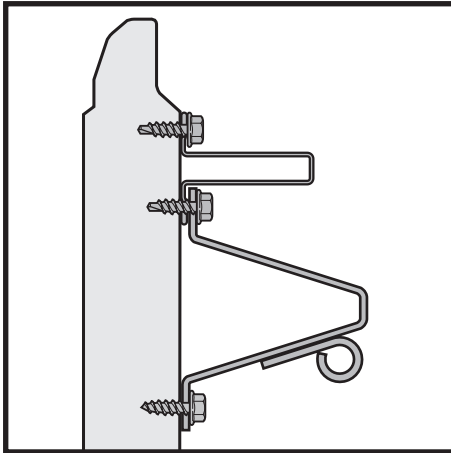

Fig. 4.2a Installation without strut

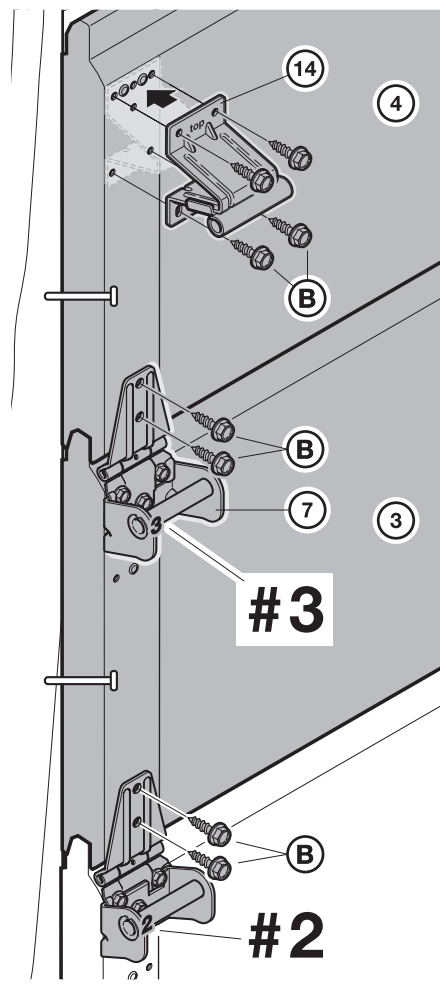
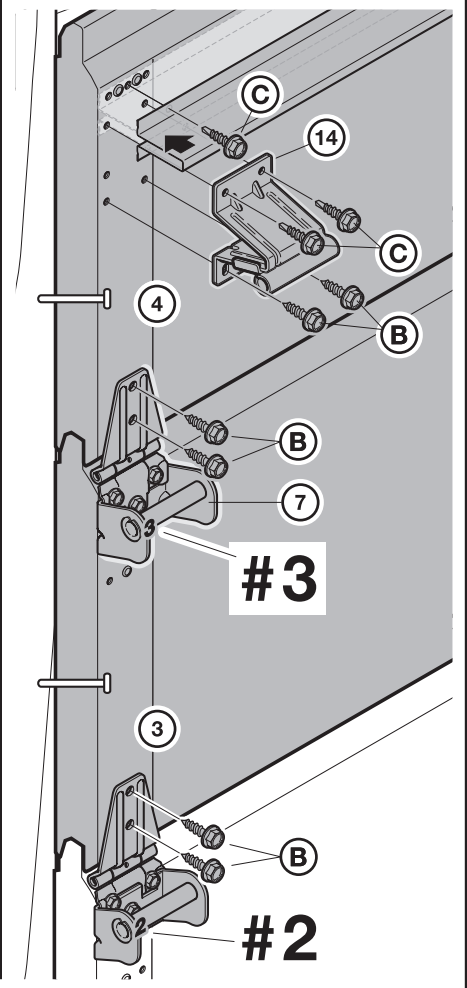
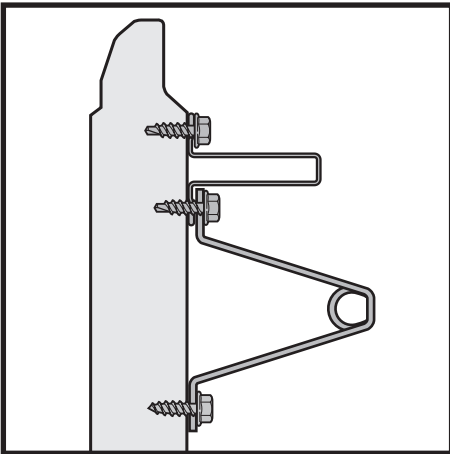

Fig. 4.2b Installation with strut



MECHANICAL INSTALLATION

Opener bracket with strut – see Fig. 4.3b



Insert side shield into the holes in the end stile as shown.

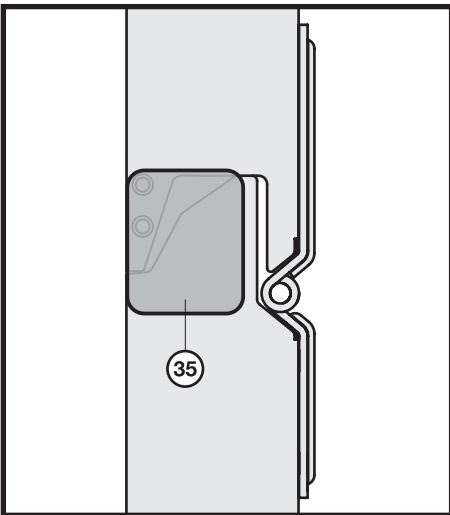

Fig. 4.3a

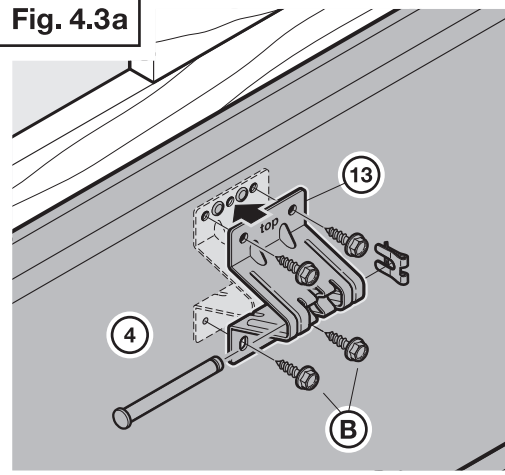

Fig. 4.3b

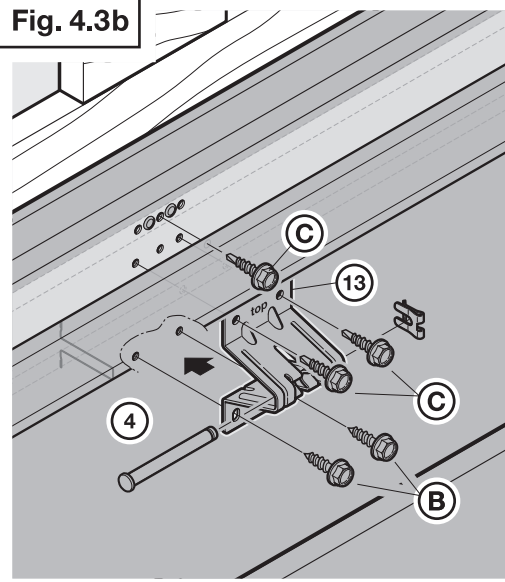

Fig. 4.4

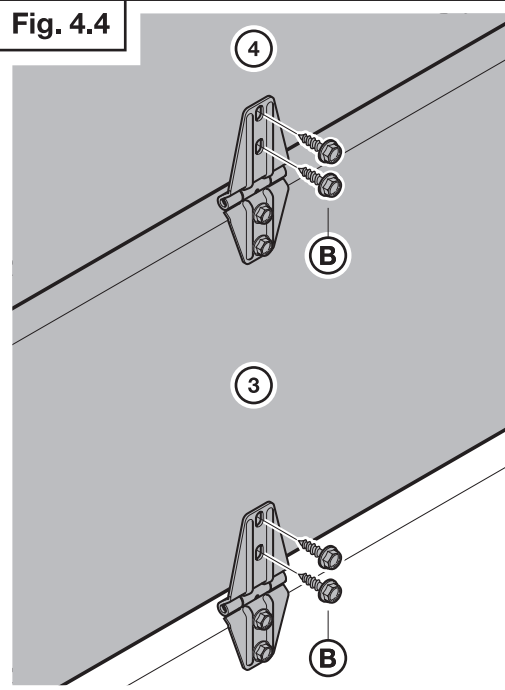
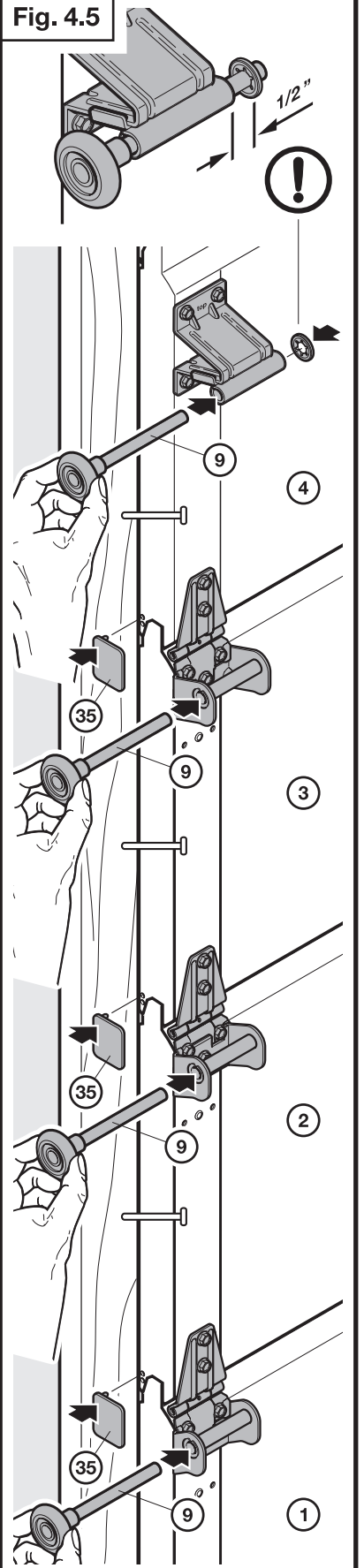
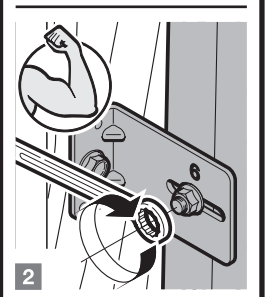
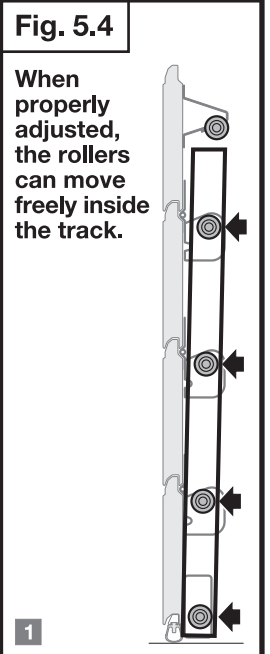
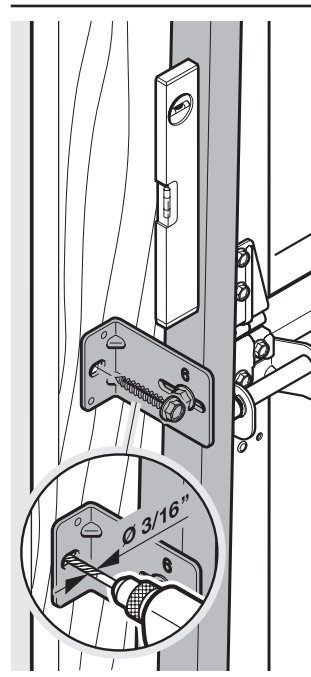
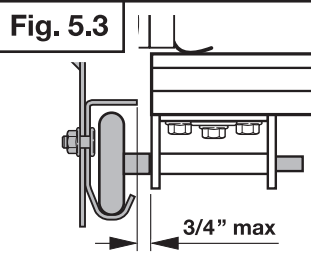
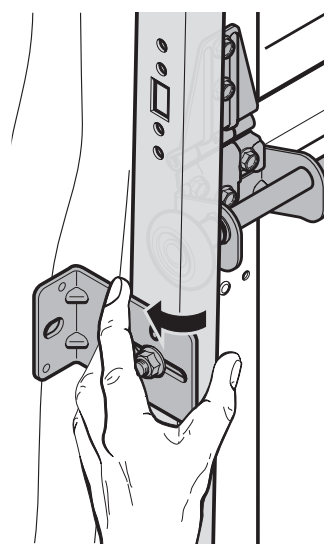
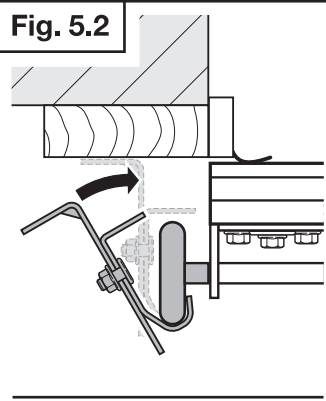
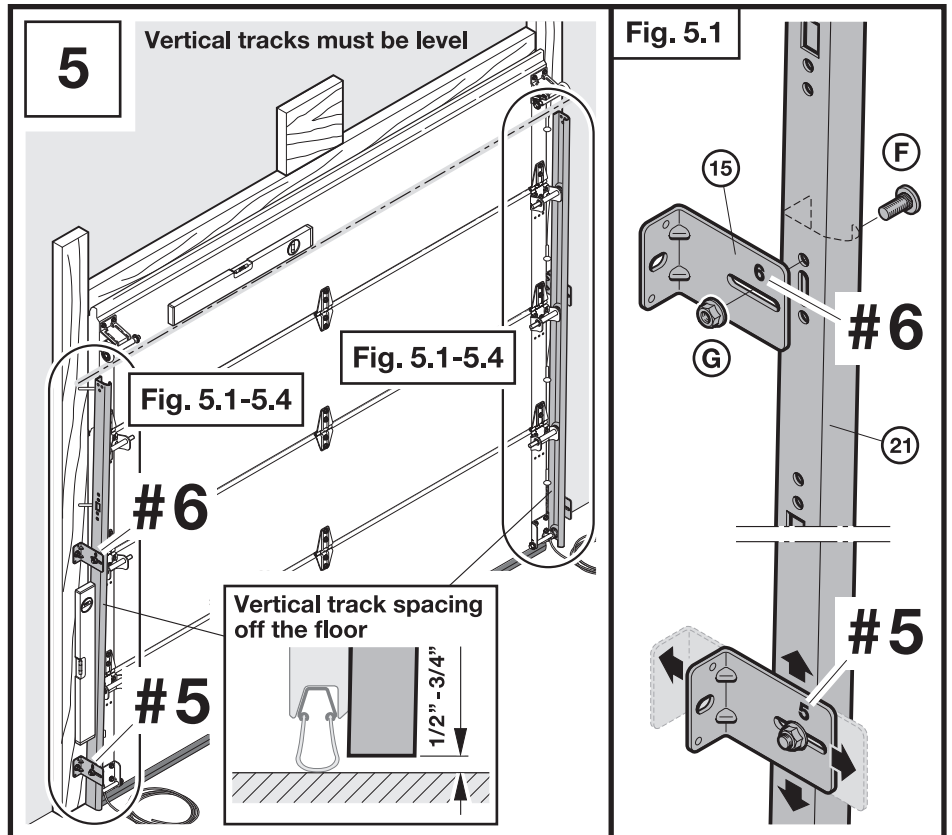

Fig. 4.5





MECHANICAL INSTALLATION

PLEASE NOTE:
TEMPORARILY SUPPORT THE BACK END OF THE TRACK USING A ROPE OR WIRE ATTACHED TO THE CEILING TO SUPPORT THE BACK END OF THE TRACK.

PLEASE NOTE:
FOR 2" THICK DOORS USE THE SECOND SLOT ON THE FLAG BRACKET (FARTHEST FROM THE JAMB).
FOR 1-3/8" THICK DOORS USE THE SLOT CLOSEST TO THE JAMB.

PLEASE NOTE:
3/8"-16 HEX NUTS ALWAYS GO ON THE OUTSIDE OF THE ASSEMBLY (AWAY FROM THE DOOR).

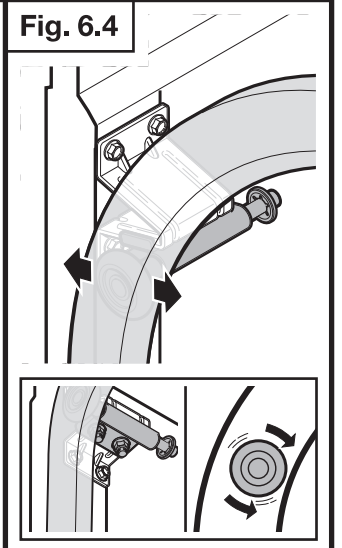
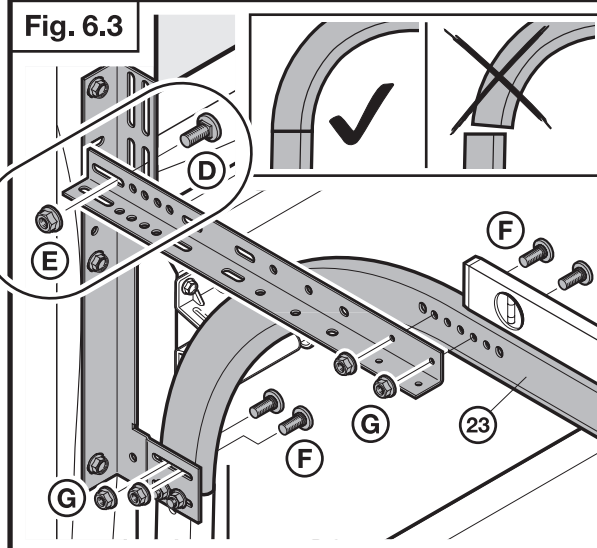
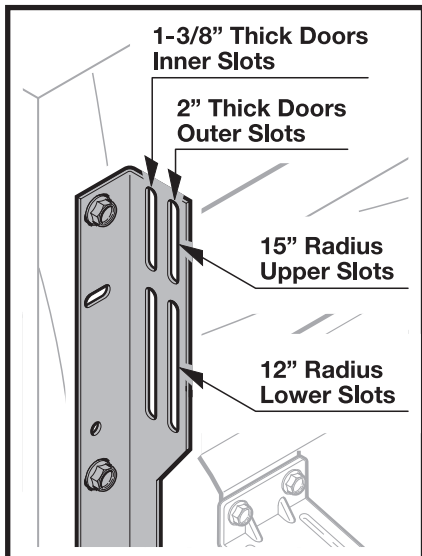
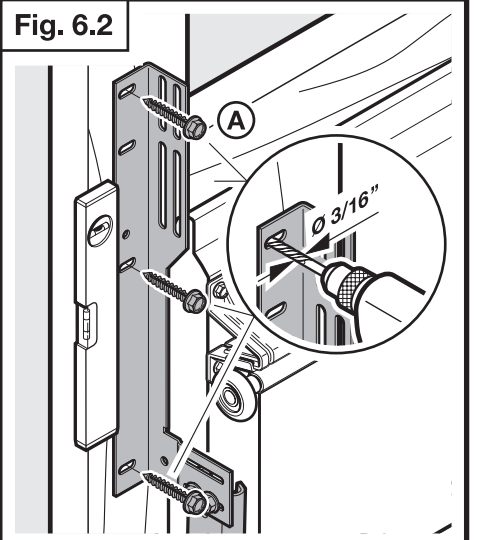
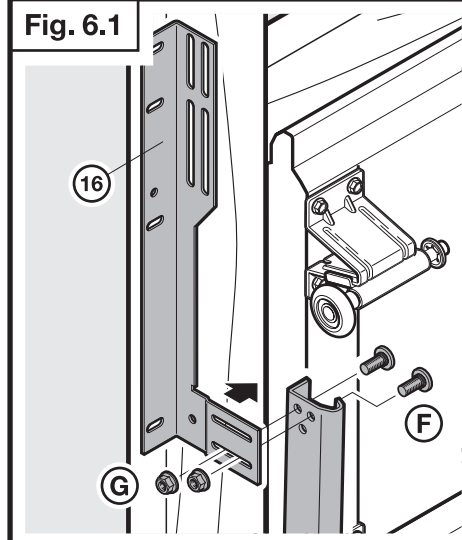
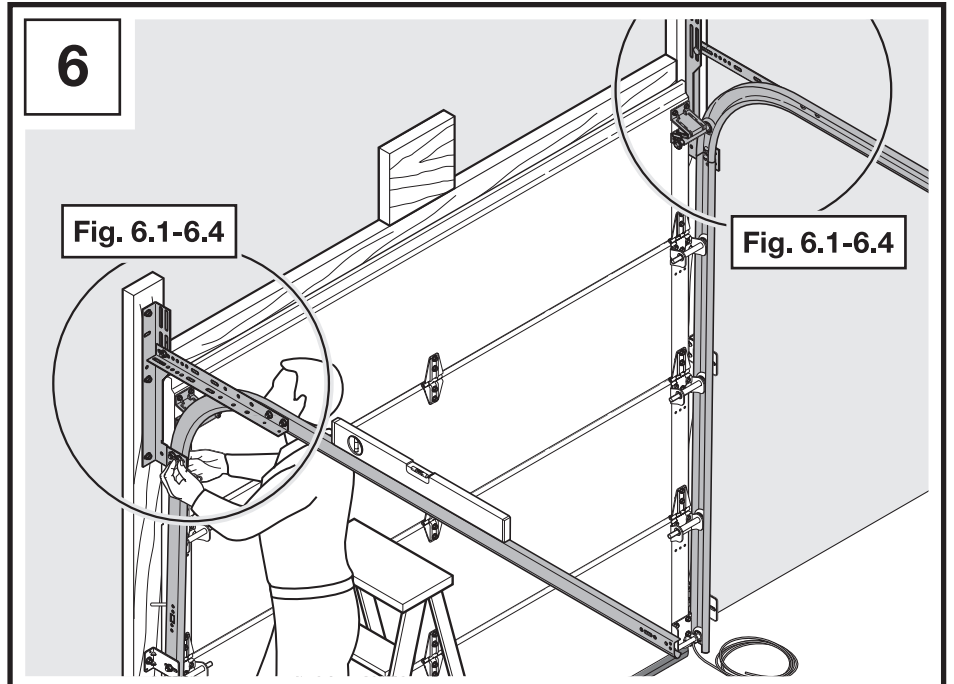

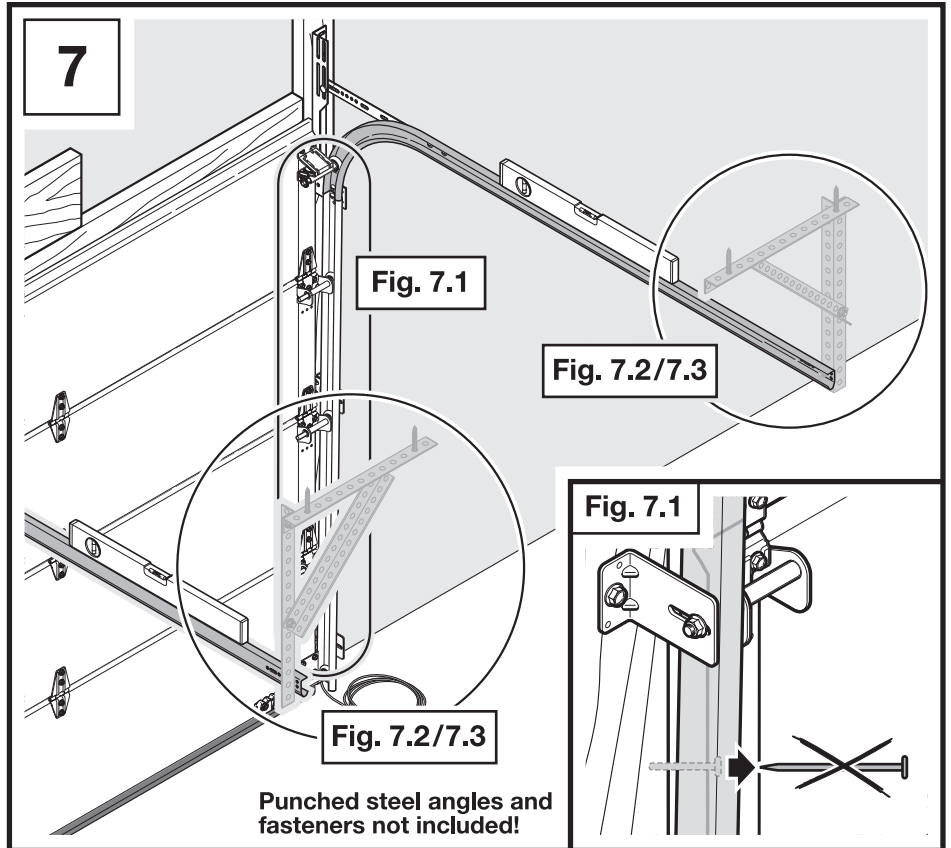

Fig. 7.2

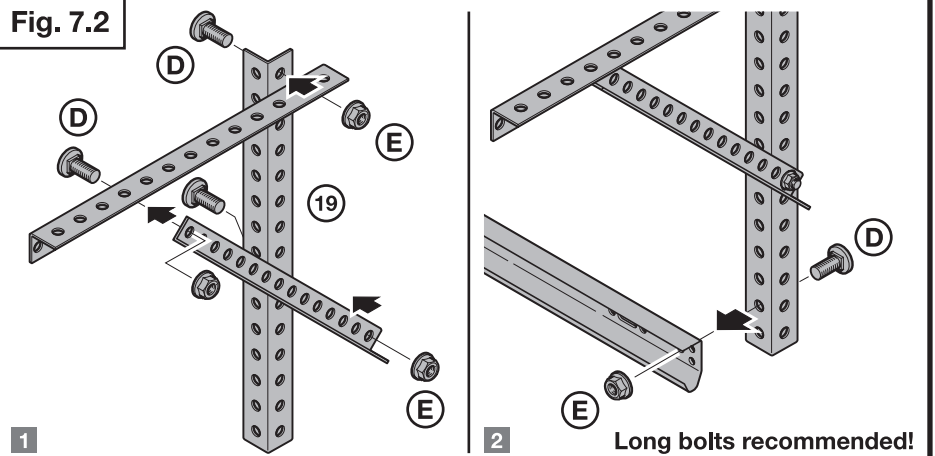
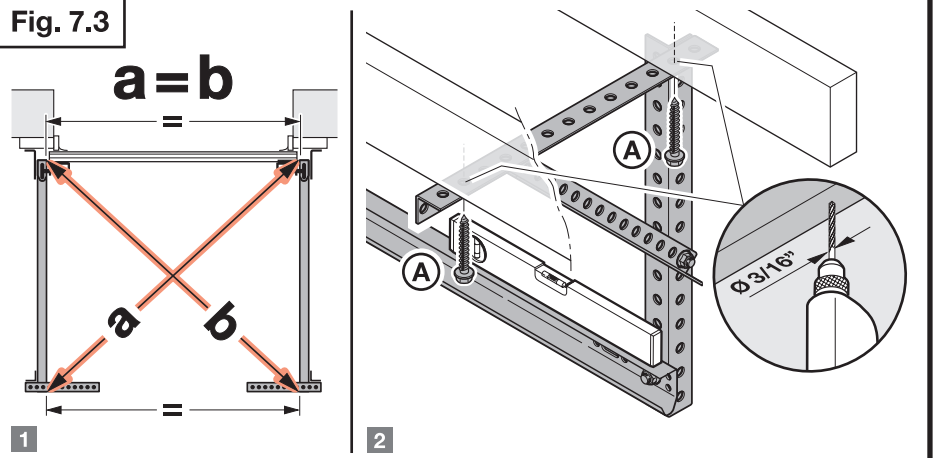
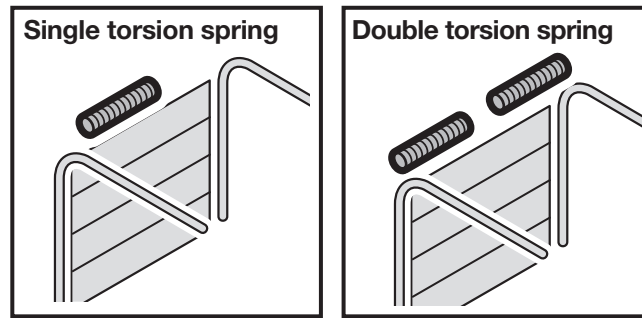
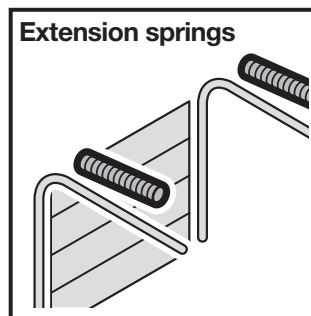

Fig. 7.3





**Single or double torsion spring
→ proceed as shown
in Fig. 8 on page 19**



**Extension springs
→ proceed as shown
in Fig. 9 on page 24**

8

Fig. 8.1-8.6

Fig. 8.1-8.6

Fig. 8.3

Fig. 8.4

Fig. 8.7

Fig. 8.1

Fig. 8.2

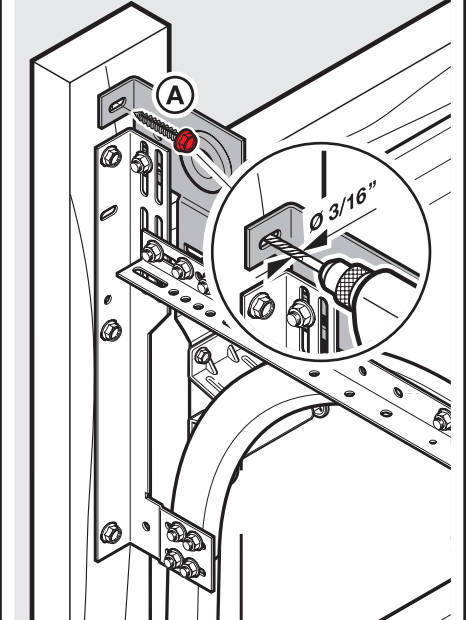
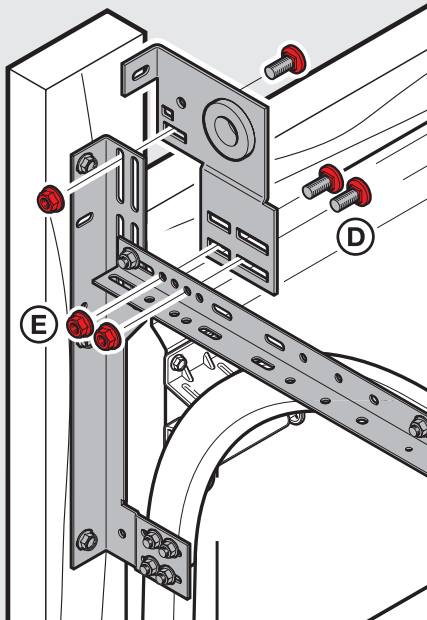

Fig. 8.3a

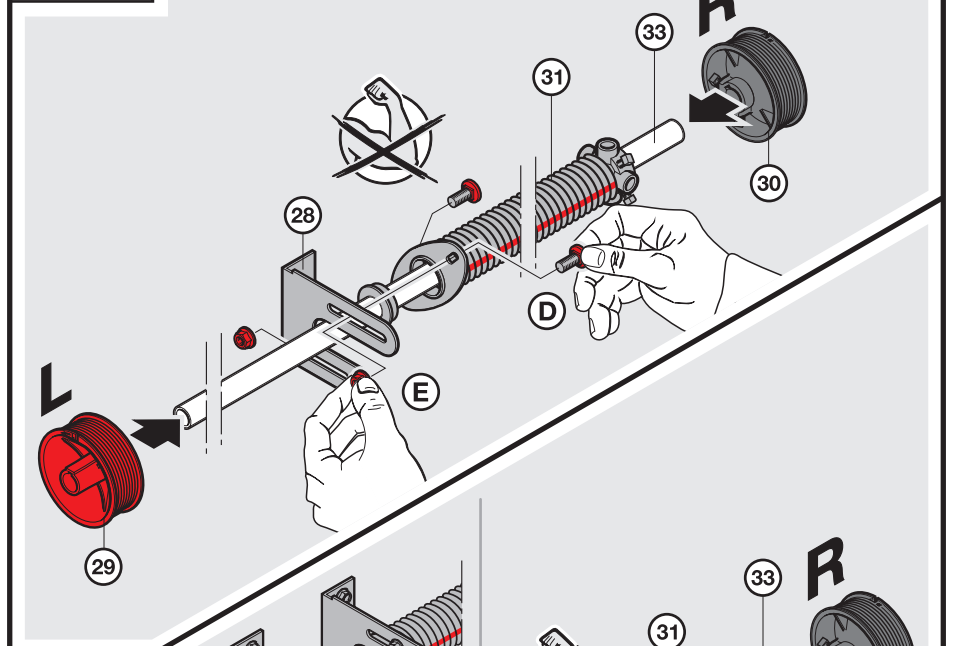

Fig. 8.3b

If multiple center bearing supports are supplied.

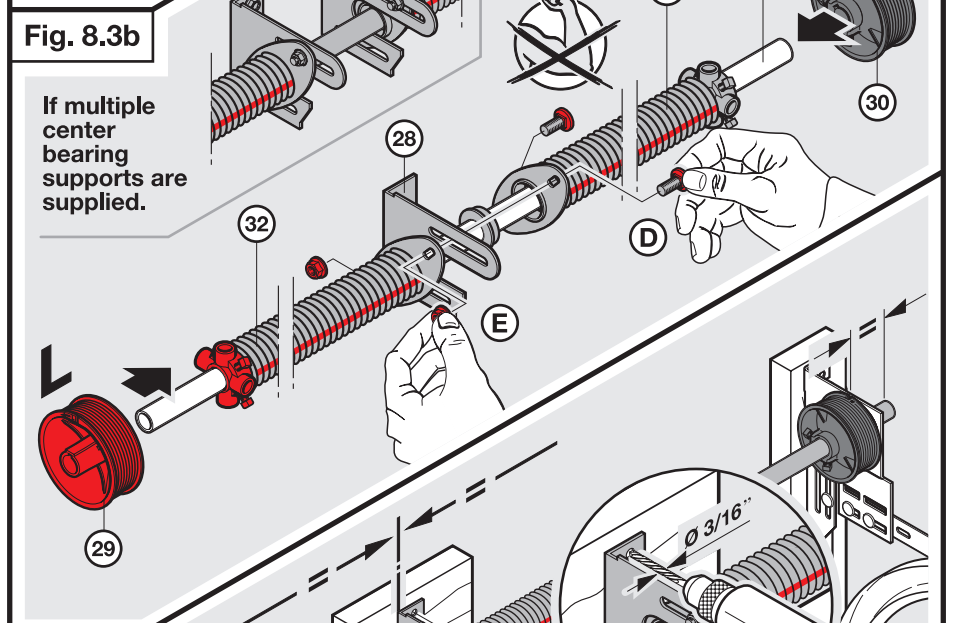
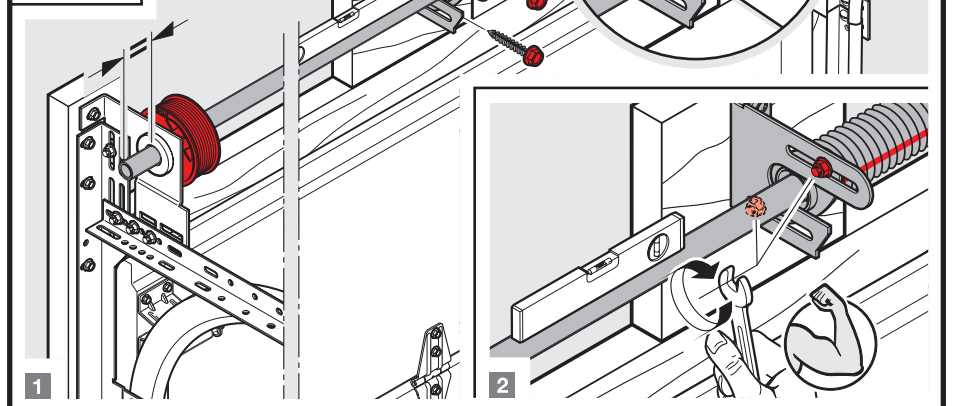

Fig. 8.4



MECHANICAL INSTALLATION

PLEASE NOTE:
TIGHTEN SET SCREW A MINIMUM
OF 1 TURN AFTER SCREW FIRST
CONTACTS TORSION SHAFT.
SET SCREW SHOULD DIMPLE SHAFT
BUT DO NOT OVER TIGHTEN AS THIS
MAY DAMAGE DRUM.

ATTACH VISE-GRIPS TO VERTICAL
TRACK DIRECTLY ABOVE THE ROLLER
ASSEMBLY TO SECURE DOOR.

Fig. 8.5

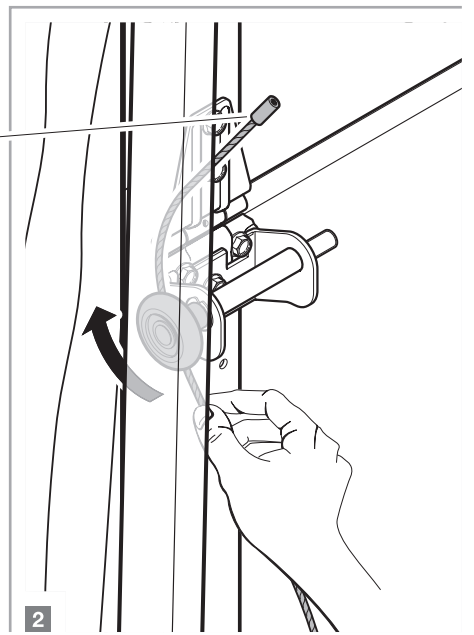
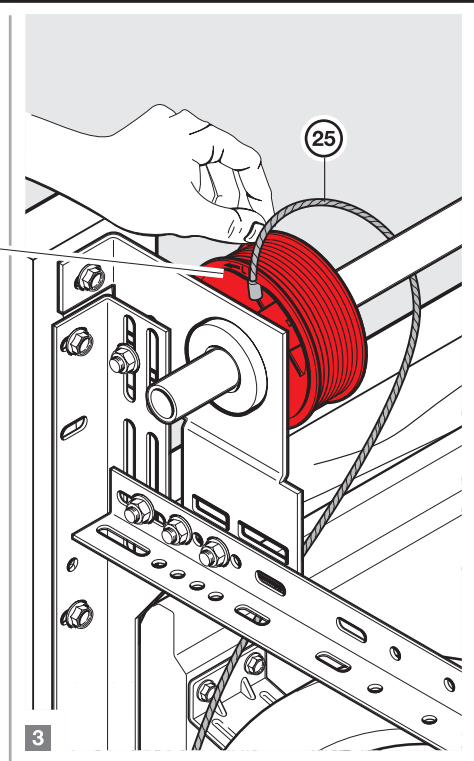
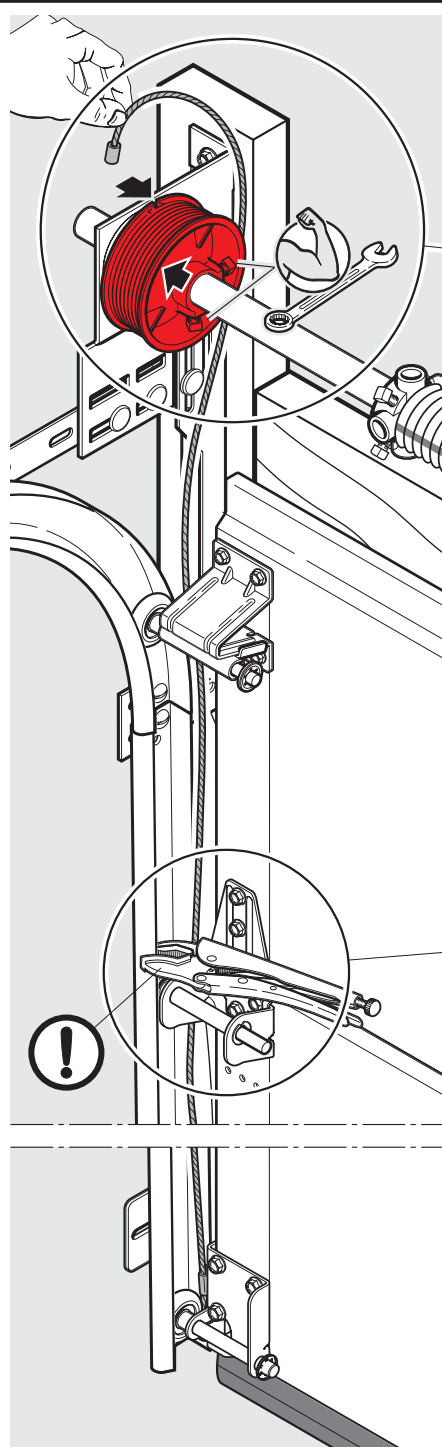
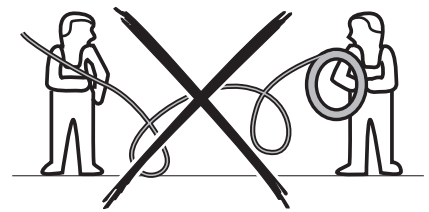

MECHANICAL INSTALLATION

PLEASE NOTE:

TIGHTEN SET SCREW A MINIMUM OF 1 TURN AFTER SCREW FIRST CONTACTS TORSION SHAFT. SET SCREW SHOULD DIMPLE SHAFT BUT DO NOT OVER TIGHTEN AS THIS MAY DAMAGE DRUM.

APPLY VICE-GRIP TO THE TORSION SHAFT WITH THE HANDLE AGAINST THE HEADER TO KEEP THE TORSION SHAFT FROM TURNING THUS KEEPING THE CABLE TIGHT AND IN THE GROOVE OF THE CABLE DRUM.

Fig. 8.6

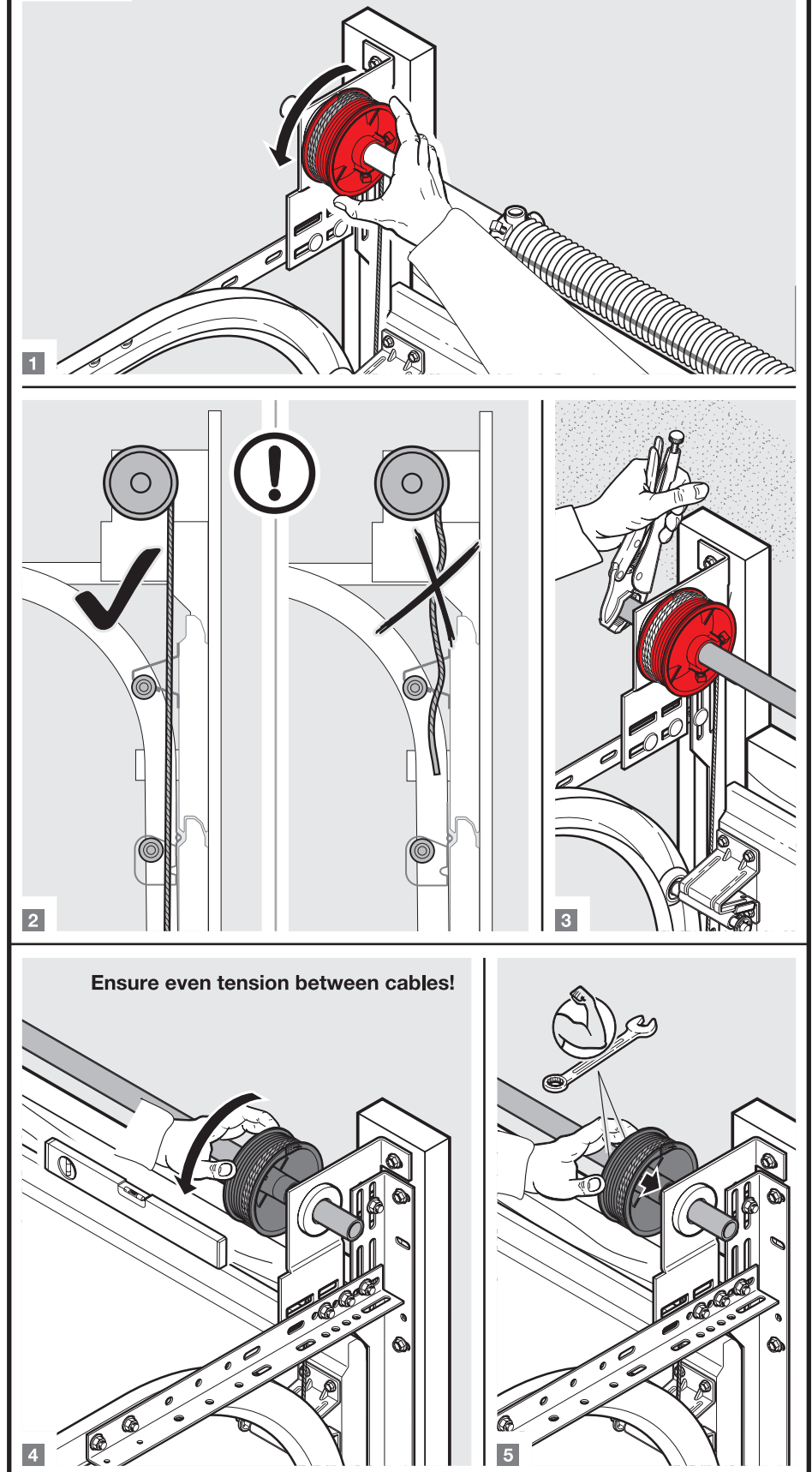



WARNING

Torsion springs can be very dangerous if they are improperly installed or mishandled. Do not attempt to install them yourself unless

- 1) you have the right tools and reasonable mechanical aptitude or experience and
- 2) you follow these Instructions very carefully.

ALWAYS USE GOOD QUALITY, SNUG FITTING, CONSTANT DIAMETER, SOLID STEEL WINDING BARS WHEN WINDING OR ADJUSTING SPRINGS. THE USE OF ANY OTHER OBJECT CAN RESULT IN SEVERE INJURY. WHEN WINDING THE SPRINGS, THE WINDING BAR MUST BE INSERTED INTO THE FULL DEPTH OF THE HOLES IN THE WINDING CONE. KEEP A FIRM GRIP ON THE WINDING BARS AT ALL TIMES. USE A STURDY LADDER AND STAND TO THE SIDE OF THE WINDING BARS.

IF YOUR DOOR HAS A TORSION SPRING ASSEMBLY, YOU MUST MAKE SURE THAT THE WOOD ANCHOR PAD (SEE DRAWING) IS FIRMLY ATTACHED TO THE GARAGE WALL AS DESCRIBED IN THE DETAILED INSTRUCTIONS ON THE NEXT PAGE. **FAILURE TO SECURELY ATTACH THE ANCHOR PAD COULD ALLOW THE SPRINGS TO VIOLENTLY PULL AWAY FROM THE GARAGE WALL, AND COULD RESULT IN SEVERE INJURY AND/OR PROPERTY DAMAGE. IN NO CASE SHOULD NAILS BE USED.**

TIGHTEN THE SET SCREWS BEFORE REMOVING THE WINDING BARS AND VISE-GRIPS. MANUALLY OPEN THE DOOR ABOUT 3-4 FEET FROM THE FLOOR. THE DOOR IS CONSIDERED REASONABLY BALANCED WITH THE SPRING ASSEMBLY IF THE DOOR DOES NOT "JUMP" OFF THE FLOOR OR "FALL" TO THE FLOOR ON ITS OWN. IF THE DOOR IS TOO HEAVY OFF THE FLOOR, INCREASE THE SPRING TENSION BY INCREASING THE NUMBER OF TURNS. IF THE DOOR IS HARD TO PULL DOWN, DECREASE THE NUMBER OF TURNS. NOTE: WHEN ADJUSTING SPRINGS BOTH THE TORSION SHAFT AND THE DOOR (SEE FIGURE 8.5 AND 8.6) MUST BE SECURED WITH VISE-GRIPS.

WARNING! THE FIRST TIME THE NEW DOOR IS BEING OPENED. IF THE TRACKS ARE NOT CORRECTLY ALIGNED OR THE BACK HANGERS ARE NOT MOUNTED SECURELY THE DOOR COULD FALL! SLOWLY RAISE THE DOOR AND CONFIRM PROPER DOOR SPACING BETWEEN TRACK AND EDGE OF DOOR (APPROXIMATELY 1/2 INCH SEE FIG. 5.3) THROUGHOUT THE TRAVEL OF THE DOOR.

NEXT, IF NECESSARY RE-POSITION THE DOORSTOP, THEN NAIL PERMANENTLY IN PLACE. NOTE: THE DOOR STOP SHOULD BE POSITIONED TIGHT ENOUGH AGAINST THE DOOR TO SEAL OUT THE ELEMENTS BUT NOT TO IMPAIR THE OPERATION OF THE DOOR.

Fig. 8.7

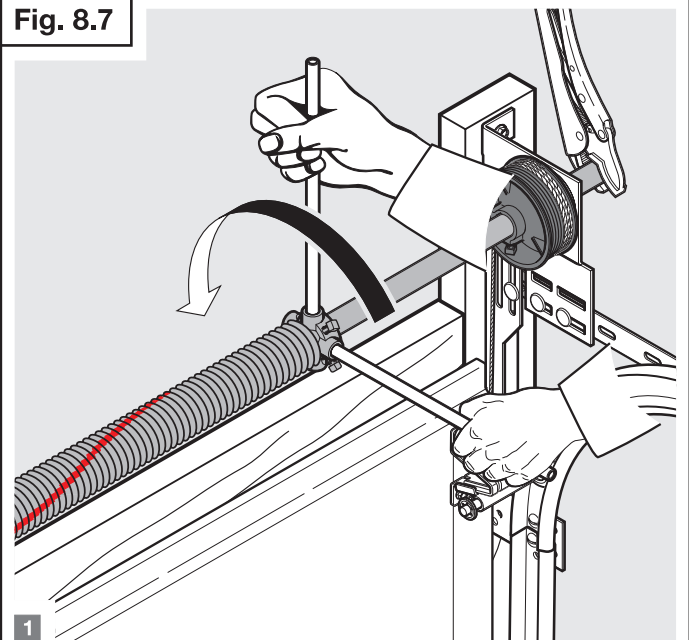

1

Refer to the label on hardware box or sections.

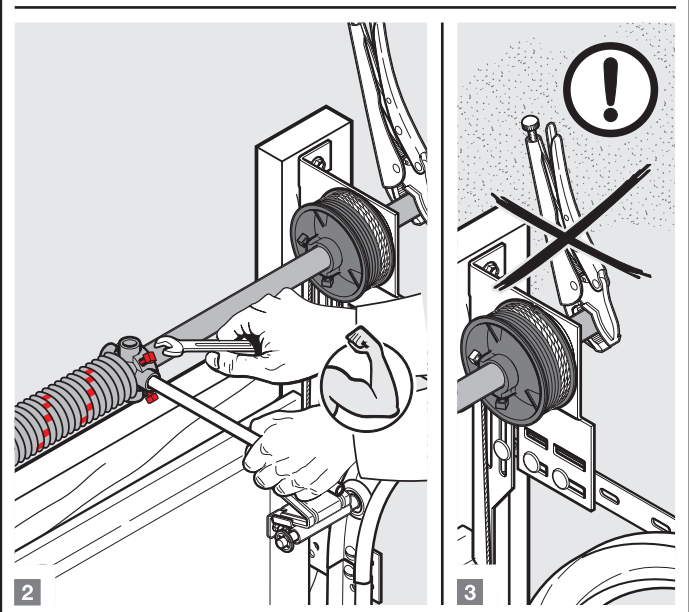
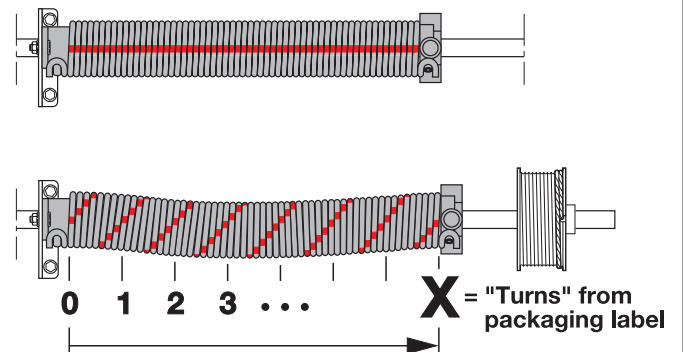

2

3

9

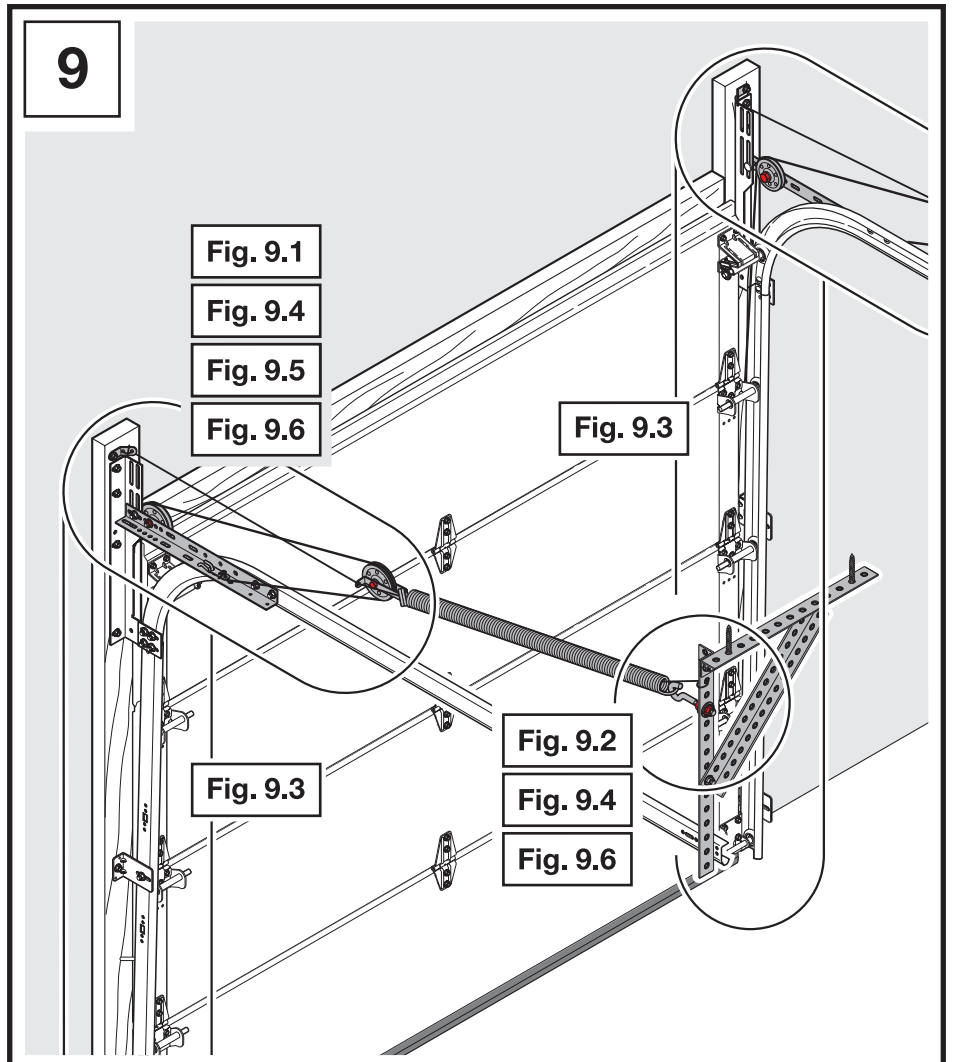

Fig. 9.1

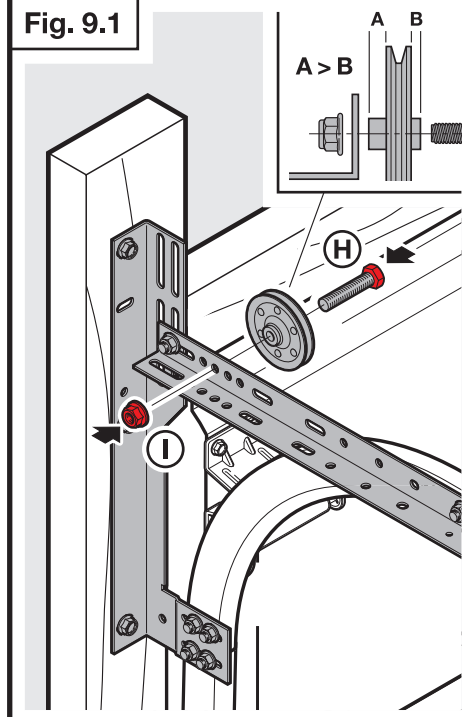

Fig. 9.2

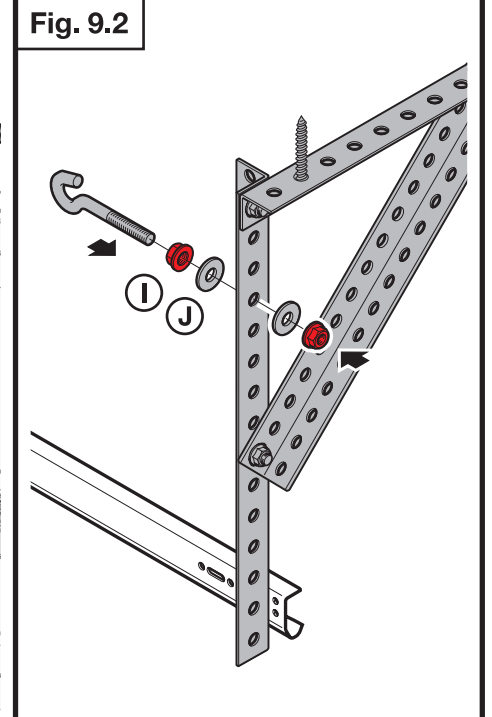
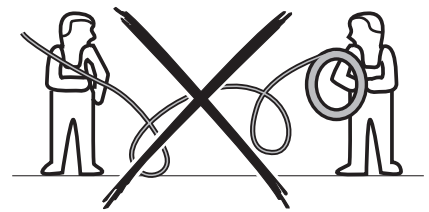
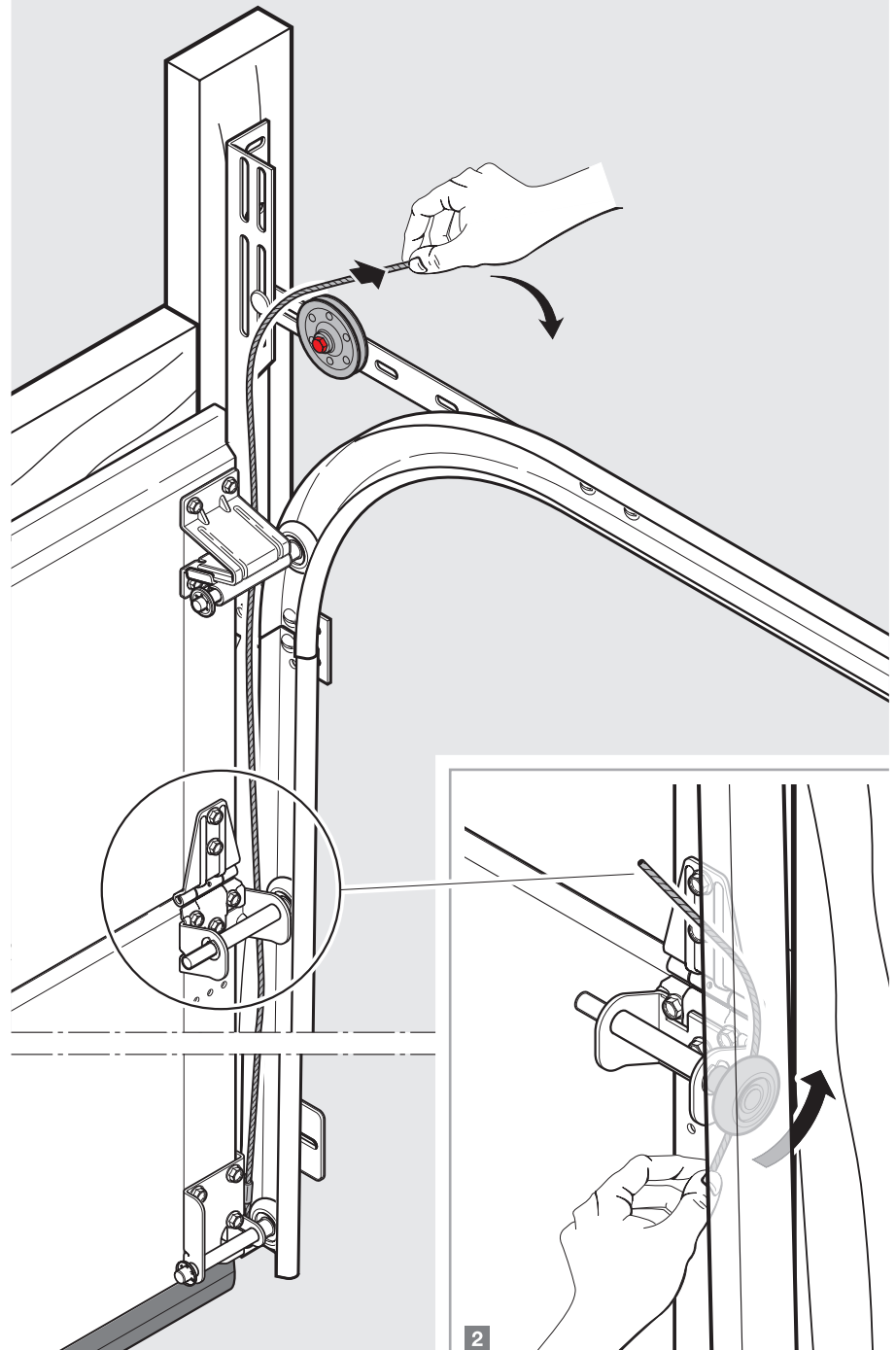

Fig. 9.3



1



2

MECHANICAL INSTALLATION

ASSISTANCE MAY BE REQUIRED FOR LIFTING THE DOOR. KNOW YOUR WEIGHT LIFTING LIMITS. SLOWLY RAISE DOOR TO THE FULL OPEN POSITION AND SECURE FROM CLOSING WITH CLAMPS.

ATTACH SHEAVE AND CLEVIS TO ONE END OF EXTENSION SPRING, ATTACH OTHER END OF EXTENSION SPRING TO EYE BOLT.

RUN CABLE UP AND OVER STATIONARY SHEAVE ON HORIZONTAL ANGLE, THEN AROUND SECOND SHEAVE AND THROUGH CLEVIS ATTACHED TO SPRING, FINALLY LOOP CABLE THROUGH CABLE END CLIP.

THE CABLE END CLIP AND THE HORIZONTAL ANGLE ARE SECURED WITH THE "S" HOOK.

LOOP SAFETY CABLE AROUND PUNCHED STEEL ANGLE AND ROUTE THROUGH SPRING AND CLEVIS HOLE. ATTACH SAFETY CABLE TO ROPE TIE ON OTHER END.

ANY REMAINING CABLE OR SAFETY CABLE SHOULD BE LOOPED AND KEPT AWAY FROM MOVING DOOR.

OPEN AND CLOSE THE DOOR A FEW TIMES TO TEST THE OPERATION OF THE DOOR. THE DOOR IS CONSIDERED REASONABLY BALANCED, WHEN IT WILL STAY (NOT FALL OR RAISE) IN A PARTIALLY OPEN POSITION. IF THE SPRINGS NEED ADJUSTMENT, PROP THE DOOR IN ITS FULL OPEN POSITION AND MOVE THE ADJUSTING "S" HOOK FORWARD FOR MORE TENSION OR BACKWARD FOR LESS TENSION. BE SURE TO ALWAYS MAINTAIN EQUAL SPRING TENSION ON BOTH SIDES.

Fig. 9.4

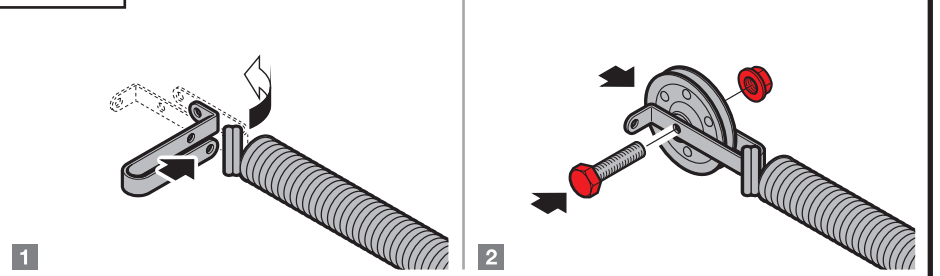

Fig. 9.5

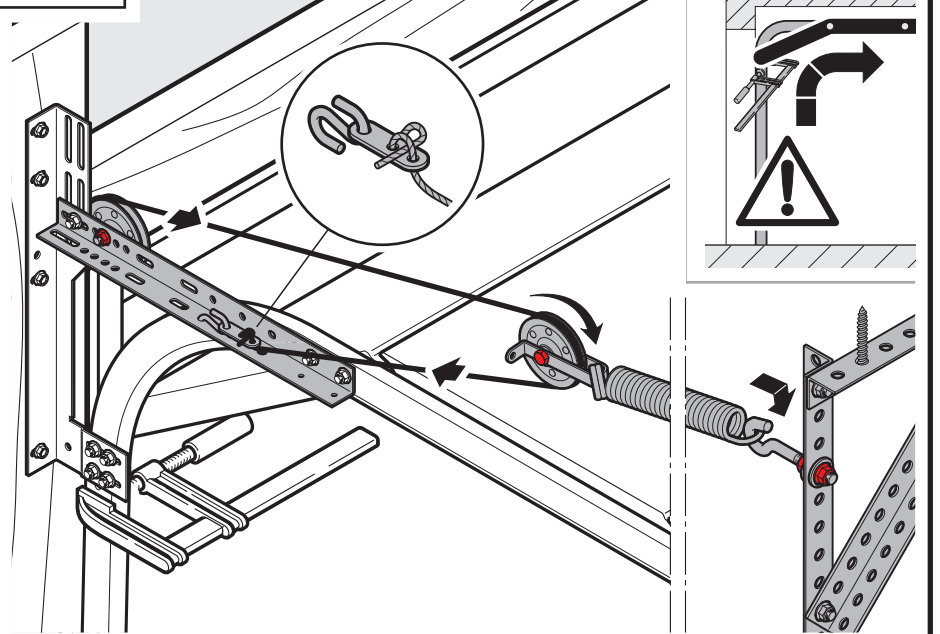
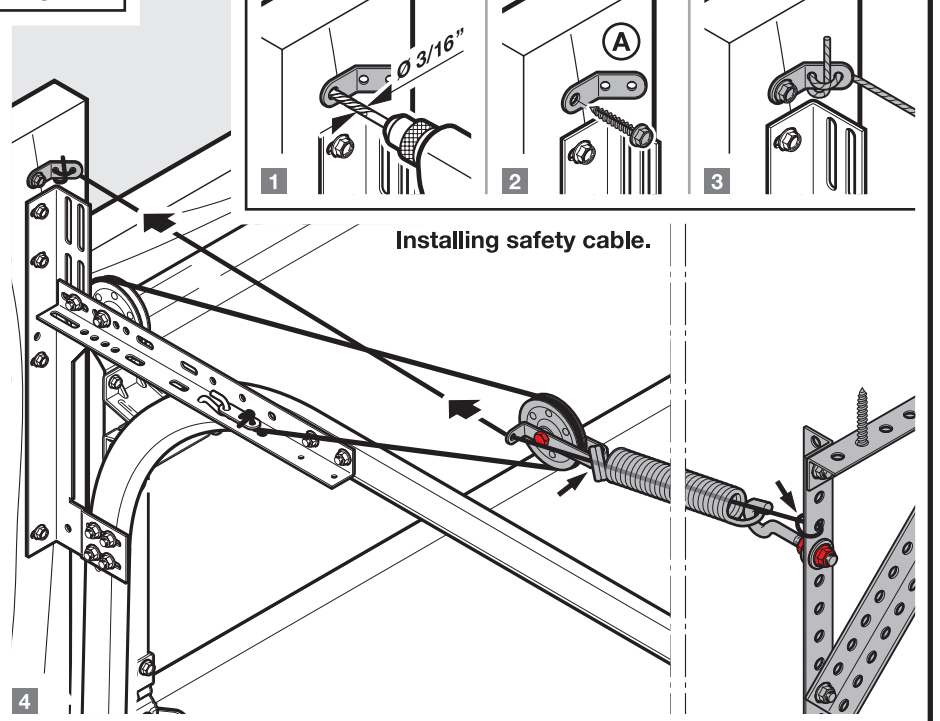

Fig. 9.6



10

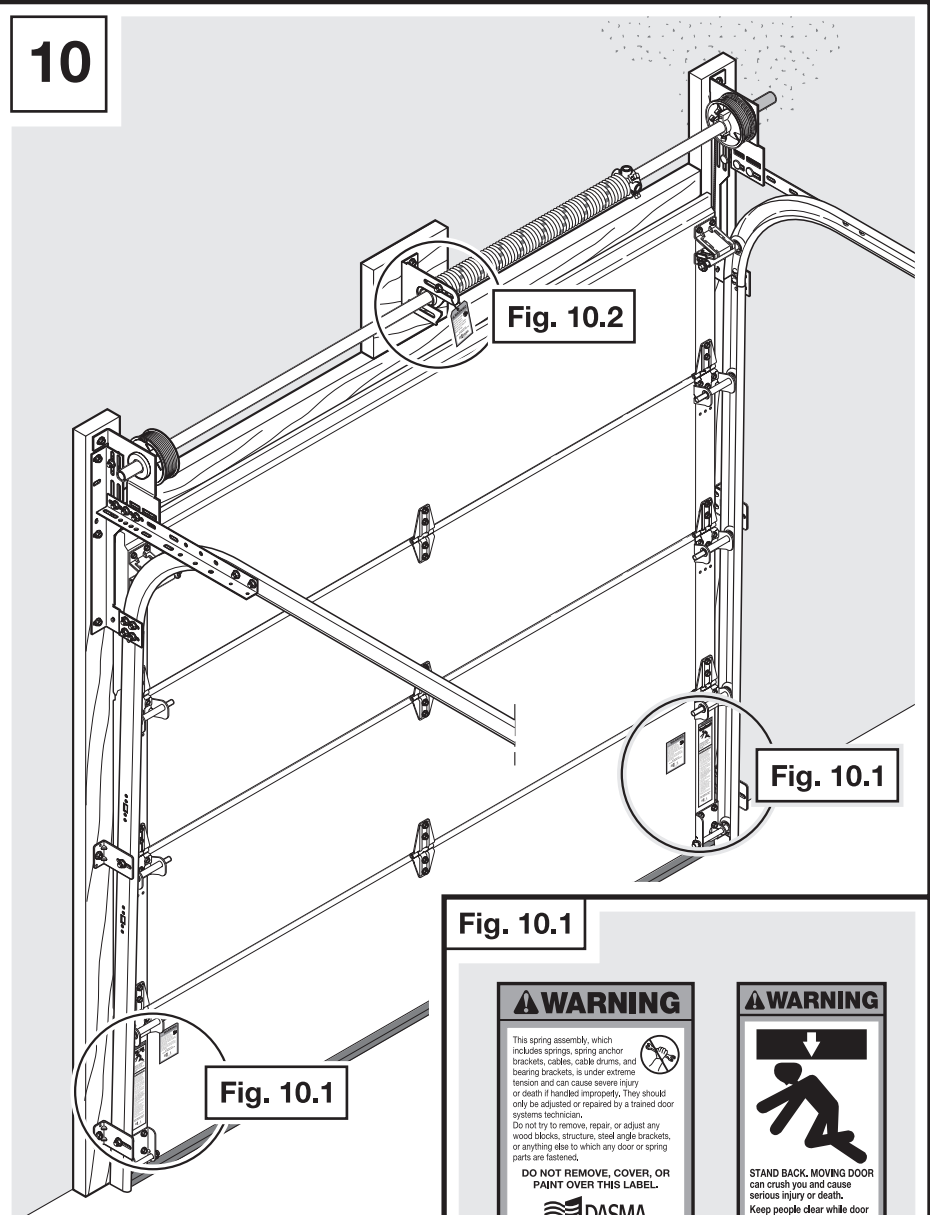

Fig. 10.1

WARNING

This spring assembly, which includes springs, spring anchor brackets, cables, cable drums, and bearing brackets, is under extreme tension and can cause severe injury or death if handled improperly. They should only be adjusted or repaired by a trained door systems technician.

Do not try to remove, repair, or adjust any wood blocks, structure, steel angle brackets, or anything else to which any door or spring parts are fastened.

DO NOT REMOVE, COVER, OR PAINT OVER THIS LABEL.

WARNING

STAND BACK. MOVING DOOR can crush you and cause serious injury or death. Keep people clear while door is moving.

- SAFETY INSTRUCTIONS**
- An overhead door is a large heavy object that moves with the help of springs under extreme tension. Moving objects and springs under tension can cause serious injuries or death. For your safety and the safety of others, follow these instructions:
1. DO NOT stand or walk under moving door. Keep door in full view and free of obstructions while operating.
 2. DO NOT allow children to operate the door or door controls.
 3. Visually inspect door and hardware monthly for worn or broken parts, and to see if it is out of adjustment or unevenly balanced.
 4. Repairs or adjustments should be made by a trained door systems technician. **SPRINGS, BOTTOM BRACKET, CABLES, AND SUPPORTS ARE UNDER EXTREME TENSION AND CAN CAUSE SERIOUS INJURIES OR DEATH.**
 5. Use handles for manually door operation.
 6. For doors with automatic openers, remove pull down ropes and remove or disable door locks. Test to see if opener has a working reverse feature. Retest monthly, following manufacturer's instructions. Top section of door may need to be reinforced to support automatic opener.
 7. Read owners manual for your door and opener, for more information.
- DO NOT REMOVE, COVER, OR PAINT OVER THIS LABEL.**
-

Fig. 10.1

Fig. 10.2

WARNING

Springs are under extreme tension and can result in serious injury or death. Do not try to adjust or repair springs.

SEE REVERSE SIDE DO NOT REMOVE THIS TAG

Maintenance

- Periodically inspect your garage door visually and test its operation on a monthly basis. Neglecting the maintenance of your door may increase the risk of personal injury, death or property damage. Visually inspect the parts on the door for wear, tear and functionality as described below.
- Check the cables for signs of wear such as fraying or tension loss. Visually inspect the cable sheaves (doors with extension springs), rivets and bearings. If in doubt, call a professional installer and have cables or other parts replaced if necessary.
- Check the bearing supports, drums and mounting hardware on the torsion springs. Check the spring tension for your own safety and convenience of operation. Disengage the door opener and lift the door to waist level and let go, the springs should hold the door in this position. Contact a professional installer to adjust the spring tension if the door rolls down. Never attempt to adjust your own springs. Extension and torsion counter balance systems are under heavy torque and tension, and need to be serviced by professional installers. Attempting to service your own springs may lead to personal injury, death and serious permanent property damage.
- Track rollers should rotate easily to provide smooth operation. Contact a service professional to make any adjustments or replace the worn parts.
- Check the track alignments and assure that the track brackets have not worked loose or bent under stress or tension. The inside of the tracks should be clear of dirt and debris to allow a smooth and easy operation.
- Check the hinges and roller carriers for loose bolts, twisting or distortion, and lubricate with a light lubricant but avoid penetrants. Inspect hardware bolts and fasteners and make sure they are tight and secure.
- Test the safety function of your opener according to manufacturer's instructions. The door must reverse to the fully open position when tested. **CONTACT A SERVICE PROFESSIONAL IMMEDIATELY IF THE TEST FAILS!**

Care and painting instructions

Steel doors

- Clean the door surface with clean water and a sponge or cloth. Use a mild soap or detergent (ph value 7) only if necessary. We recommend that you wash your door regularly if you live near salt water environment. Avoid contact with abrasive or corrosive substances, such as acids, alkaline liquids, de-icing salt etc.
- Clean your door windows with care. Always use a soft cloth with a mild non-abrasive detergent to prevent scratches. A temporary condensation between the double panes may occur and is not considered to be a failed product flaw.
- Follow these instructions should you desire to paint your door.
Wash and scrub the surface with a sponge or non-abrasive brush until clean, using a solution consisting of the following proportions:
 - 3 quarts water
 - 1/3 cup powdered type laundry detergent (do not use liquid soap)
 - 2/3 cup tri-sodium phosphate (tsp) (optional where available)
 - If mildew is present, add 1 quart sodium hypochlorite (5% solution, bleach)
 - Rinse door surface well with water and allow to dry
 - Any loose or blistered areas must be feather edged and primed prior to repainting
 - Repaint according to the paint manufacturer's instructions, with any good quality latex type exterior metal building paint only. Do not use interior, automotive, or other hot solvent type paints. Avoid dark colors. Otherwise sections might heat up in the sun causing panel distortion, which might impair door function and quality.
- Our factory-applied vinyl overlays do not require painting but can be painted if desired with vinyl-safe paint. For cleaning, glass cleaners may be used but, to keep the finish intact, the cleaning solution should not be left to stand on the components for an extended period of time. Apply the cleaning solution and immediately wipe dry. Do not use harsh cleaners with glycol ethers or ethanol type solvents and/or isopropyl alcohol, citrus cleaners, abrasive cleaners, and solvents such as acetone, paint remover or lacquer thinner.

Troubleshooting

Please refer to section 'Maintenance', if your garage door does not operate smoothly and contact a professional installer for assistance before attempting any repair, replacement, or adjustment of worn, broken or missing parts, etc. by yourself. For your own safety do not attempt to perform any repairs and contact a professional installer instead. Failure to follow these instructions may cause serious personal injury or death.

Everything you've always wanted in a garage door, and more.



German Engineered, American Made

Our promise to you.

As one of the world's leading manufacturers of doors, we're committed to providing the best quality, value, and selection. Whether residential or commercial, whether steel or high density polyethylene,

whether traditional or contemporary, we have the door you're looking for. Each Hörmann door gives you the perfect array of benefits and options, with the drive to match.



Hörmann Flexon LLC, Burgettstown, PA
Headquarters and Manufacturing Plant



High Performance Doors and Dock Equipment

For assistance call 1-800-365-3667

Environmental commitment has been part of our corporate culture for decades, from our manufacturing processes to the products we make.

In everything we do, we strive to minimize energy and resource use, through efficient processes long-lasting quality and innovative engineering.

